

DAQ

NI 6034E/6035E/6036E

User Manual

Multifunction I/O Devices

Worldwide Technical Support and Product Information

ni.com

National Instruments Corporate Headquarters

11500 North Mopac Expressway Austin, Texas 78759-3504 USA Tel: 512 683 0100

Worldwide Offices

Australia 03 9879 5166, Austria 0662 45 79 90 0, Belgium 02 757 00 20, Brazil 011 3262 3599,
Canada (Calgary) 403 274 9391, Canada (Montreal) 514 288 5722, Canada (Ottawa) 613 233 5949,
Canada (Québec) 514 694 8521, Canada (Toronto) 905 785 0085, China 86 21 6555 7838,
Czech Republic 02 2423 5774, Denmark 45 76 26 00, Finland 09 725 725 11, France 01 48 14 24 24,
Germany 089 741 31 30, Greece 01 42 96 427, Hong Kong 2645 3186, India 91 80 4190000,
Israel 03 6393737, Italy 02 413091, Japan 03 5472 2970, Korea 02 3451 3400, Malaysia 603 9596711,
Mexico 001 800 010 0793, Netherlands 0348 433466, New Zealand 09 914 0488, Norway 32 27 73 00,
Poland 22 3390 150, Portugal 210 311 210, Russia 095 238 7139, Singapore 65 6 226 5886,
Slovenia 3 425 4200, South Africa 11 805 8197, Spain 91 640 0085, Sweden 08 587 895 00,
Switzerland 056 200 51 51, Taiwan 02 2528 7227, United Kingdom 01635 523545

For further support information, see the *Technical Support and Professional Services* appendix. To comment on the documentation, send email to techpubs@ni.com.

Important Information

Warranty

The NI 6034E, NI 6035E, and NI 6036E are warranted against defects in materials and workmanship for a period of one year from the date of shipment, as evidenced by receipts or other documentation. National Instruments will, at its option, repair or replace equipment that proves to be defective during the warranty period. This warranty includes parts and labor.

The media on which you receive National Instruments software are warranted not to fail to execute programming instructions, due to defects in materials and workmanship, for a period of 90 days from date of shipment, as evidenced by receipts or other documentation. National Instruments will, at its option, repair or replace software media that do not execute programming instructions if National Instruments receives notice of such defects during the warranty period. National Instruments does not warrant that the operation of the software shall be uninterrupted or error free.

A Return Material Authorization (RMA) number must be obtained from the factory and clearly marked on the outside of the package before any equipment will be accepted for warranty work. National Instruments will pay the shipping costs of returning to the owner parts which are covered by warranty.

National Instruments believes that the information in this document is accurate. The document has been carefully reviewed for technical accuracy. In the event that technical or typographical errors exist, National Instruments reserves the right to make changes to subsequent editions of this document without prior notice to holders of this edition. The reader should consult National Instruments if errors are suspected. In no event shall National Instruments be liable for any damages arising out of or related to this document or the information contained in it.

EXCEPT AS SPECIFIED HEREIN, NATIONAL INSTRUMENTS MAKES NO WARRANTIES, EXPRESS OR IMPLIED, AND SPECIFICALLY DISCLAIMS ANY WARRANTY OF MERCHANTABILITY OR FITNESS FOR A PARTICULAR PURPOSE. CUSTOMER'S RIGHT TO RECOVER DAMAGES CAUSED BY FAULT OR NEGLIGENCE ON THE PART OF NATIONAL INSTRUMENTS SHALL BE LIMITED TO THE AMOUNT THEREOF PAID BY THE CUSTOMER. NATIONAL INSTRUMENTS WILL NOT BE LIABLE FOR DAMAGES RESULTING FROM LOSS OF DATA, PROFITS, USE OF PRODUCTS, OR INCIDENTAL OR CONSEQUENTIAL DAMAGES, EVEN IF ADVISED OF THE POSSIBILITY THEREOF. This limitation of the liability of National Instruments will apply regardless of the form of action, whether in contract or tort, including negligence. Any action against National Instruments must be brought within one year after the cause of action accrues. National Instruments shall not be liable for any delay in performance due to causes beyond its reasonable control. The warranty provided herein does not cover damages, defects, malfunctions, or service failures caused by owner's failure to follow the National Instruments installation, operation, or maintenance instructions; owner's modification of the product; owner's abuse, misuse, or negligent acts; and power failure or surges, fire, flood, accident, actions of third parties, or other events outside reasonable control.

Copyright

Under the copyright laws, this publication may not be reproduced or transmitted in any form, electronic or mechanical, including photocopying, recording, storing in an information retrieval system, or translating, in whole or in part, without the prior written consent of National Instruments Corporation.

Trademarks

CVI™, DAQCard™, DAQ-STC™, LabVIEW™, Measurement Studio™, MITE™, MXI™, National Instruments™, NI™, ni.com™, NI-DAQ™, NI-PGIA™, RTSI™, and SCXI™ are trademarks of National Instruments Corporation.

Product and company names mentioned herein are trademarks or trade names of their respective companies.

Patents

For patents covering National Instruments products, refer to the appropriate location: **Help»Patents** in your software, the `patents.txt` file on your CD, or ni.com/patents.

WARNING REGARDING USE OF NATIONAL INSTRUMENTS PRODUCTS

(1) NATIONAL INSTRUMENTS PRODUCTS ARE NOT DESIGNED WITH COMPONENTS AND TESTING FOR A LEVEL OF RELIABILITY SUITABLE FOR USE IN OR IN CONNECTION WITH SURGICAL IMPLANTS OR AS CRITICAL COMPONENTS IN ANY LIFE SUPPORT SYSTEMS WHOSE FAILURE TO PERFORM CAN REASONABLY BE EXPECTED TO CAUSE SIGNIFICANT INJURY TO A HUMAN.

(2) IN ANY APPLICATION, INCLUDING THE ABOVE, RELIABILITY OF OPERATION OF THE SOFTWARE PRODUCTS CAN BE IMPAIRED BY ADVERSE FACTORS, INCLUDING BUT NOT LIMITED TO FLUCTUATIONS IN ELECTRICAL POWER SUPPLY, COMPUTER HARDWARE MALFUNCTIONS, COMPUTER OPERATING SYSTEM SOFTWARE FITNESS, FITNESS OF COMPILERS AND DEVELOPMENT SOFTWARE USED TO DEVELOP AN APPLICATION, INSTALLATION ERRORS, SOFTWARE AND HARDWARE COMPATIBILITY PROBLEMS, MALFUNCTIONS OR FAILURES OF ELECTRONIC MONITORING OR CONTROL DEVICES, TRANSIENT FAILURES OF ELECTRONIC SYSTEMS (HARDWARE AND/OR SOFTWARE), UNANTICIPATED USES OR MISUSES, OR ERRORS ON THE PART OF THE USER OR APPLICATIONS DESIGNER (ADVERSE FACTORS SUCH AS THESE ARE HEREAFTER COLLECTIVELY TERMED "SYSTEM FAILURES"). ANY APPLICATION WHERE A SYSTEM FAILURE WOULD CREATE A RISK OF HARM TO PROPERTY OR PERSONS (INCLUDING THE RISK OF BODILY INJURY AND DEATH) SHOULD NOT BE RELIANT SOLELY UPON ONE FORM OF ELECTRONIC SYSTEM DUE TO THE RISK OF SYSTEM FAILURE. TO AVOID DAMAGE, INJURY, OR DEATH, THE USER OR APPLICATION DESIGNER MUST TAKE REASONABLY PRUDENT STEPS TO PROTECT AGAINST SYSTEM FAILURES, INCLUDING BUT NOT LIMITED TO BACK-UP OR SHUT DOWN MECHANISMS. BECAUSE EACH END-USER SYSTEM IS CUSTOMIZED AND DIFFERS FROM NATIONAL INSTRUMENTS' TESTING PLATFORMS AND BECAUSE A USER OR APPLICATION DESIGNER MAY USE NATIONAL INSTRUMENTS PRODUCTS IN COMBINATION WITH OTHER PRODUCTS IN A MANNER NOT EVALUATED OR CONTEMPLATED BY NATIONAL INSTRUMENTS, THE USER OR APPLICATION DESIGNER IS ULTIMATELY RESPONSIBLE FOR VERIFYING AND VALIDATING THE SUITABILITY OF NATIONAL INSTRUMENTS PRODUCTS WHENEVER NATIONAL INSTRUMENTS PRODUCTS ARE INCORPORATED IN A SYSTEM OR APPLICATION, INCLUDING, WITHOUT LIMITATION, THE APPROPRIATE DESIGN, PROCESS AND SAFETY LEVEL OF SUCH SYSTEM OR APPLICATION.

Compliance

FCC/Canada Radio Frequency Interference Compliance*

Determining FCC Class

The Federal Communications Commission (FCC) has rules to protect wireless communications from interference. The FCC places digital electronics into two classes. These classes are known as Class A (for use in industrial-commercial locations only) or Class B (for use in residential or commercial locations). Depending on where it is operated, this product could be subject to restrictions in the FCC rules. (In Canada, the Department of Communications (DOC), of Industry Canada, regulates wireless interference in much the same way.)

Digital electronics emit weak signals during normal operation that can affect radio, television, or other wireless products. By examining the product you purchased, you can determine the FCC Class and therefore which of the two FCC/DOC Warnings apply in the following sections. (Some products may not be labeled at all for FCC; if so, the reader should then assume these are Class A devices.)

FCC Class A products only display a simple warning statement of one paragraph in length regarding interference and undesired operation. Most of our products are FCC Class A. The FCC rules have restrictions regarding the locations where FCC Class A products can be operated.

FCC Class B products display either a FCC ID code, starting with the letters **EXN**, or the FCC Class B compliance mark that appears as shown here on the right.

Consult the FCC Web site <http://www.fcc.gov> for more information.

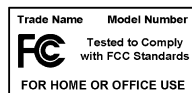

FCC/DOC Warnings

This equipment generates and uses radio frequency energy and, if not installed and used in strict accordance with the instructions in this manual and the CE Mark Declaration of Conformity**, may cause interference to radio and television reception. Classification requirements are the same for the Federal Communications Commission (FCC) and the Canadian Department of Communications (DOC).

Changes or modifications not expressly approved by National Instruments could void the user's authority to operate the equipment under the FCC Rules.

Class A

Federal Communications Commission

This equipment has been tested and found to comply with the limits for a Class A digital device, pursuant to part 15 of the FCC Rules. These limits are designed to provide reasonable protection against harmful interference when the equipment is operated in a commercial environment. This equipment generates, uses, and can radiate radio frequency energy and, if not installed and used in accordance with the instruction manual, may cause harmful interference to radio communications. Operation of this equipment in a residential area is likely to cause harmful interference in which case the user will be required to correct the interference at his own expense.

Canadian Department of Communications

This Class A digital apparatus meets all requirements of the Canadian Interference-Causing Equipment Regulations.

Cet appareil numérique de la classe A respecte toutes les exigences du Règlement sur le matériel brouilleur du Canada.

Class B

Federal Communications Commission

This equipment has been tested and found to comply with the limits for a Class B digital device, pursuant to part 15 of the FCC Rules. These limits are designed to provide reasonable protection against harmful interference in a residential installation. This equipment generates, uses and can radiate radio frequency energy and, if not installed and used in accordance with the instructions, may cause harmful interference to radio communications. However, there is no guarantee that interference will not occur in a particular installation. If this equipment does cause harmful interference to radio or television reception, which can be determined by turning the equipment off and on, the user is encouraged to try to correct the interference by one or more of the following measures:

- Reorient or relocate the receiving antenna.
- Increase the separation between the equipment and receiver.
- Connect the equipment into an outlet on a circuit different from that to which the receiver is connected.
- Consult the dealer or an experienced radio/TV technician for help.

Canadian Department of Communications

This Class B digital apparatus meets all requirements of the Canadian Interference-Causing Equipment Regulations.

Cet appareil numérique de la classe B respecte toutes les exigences du Règlement sur le matériel brouilleur du Canada.

Compliance to EU Directives

Readers in the European Union (EU) must refer to the Manufacturer's Declaration of Conformity (DoC) for information** pertaining to the CE Mark compliance scheme. The Manufacturer includes a DoC for most every hardware product except for those bought for OEMs, if also available from an original manufacturer that also markets in the EU, or where compliance is not required as for electrically benign apparatus or cables.

To obtain the DoC for this product, click **Declaration of Conformity** at ni.com/hardref.nsf/. This Web site lists the DoCs by product family. Select the appropriate product family, followed by your product, and a link to the DoC appears in Adobe Acrobat format. Click the Acrobat icon to download or read the DoC.

* Certain exemptions may apply in the USA, see FCC Rules §15.103 **Exempted devices**, and §15.105(c). Also available in sections of CFR 47.

** The CE Mark Declaration of Conformity will contain important supplementary information and instructions for the user or installer.

Contents

About This Manual

Conventions Used in This Manual.....	xi
Related Documentation.....	xii

Chapter 1

Introduction

About the NI 6034E/6035E/6036E.....	1-1
What You Need to Get Started	1-2
Software Programming Choices	1-2
NI-DAQ.....	1-2
National Instruments ADE Software.....	1-3
Optional Equipment.....	1-4
Unpacking.....	1-5
Safety Information	1-5

Chapter 2

Installing and Configuring the NI 6034E/6035E/6036E

Installing the Software	2-1
Installing the Hardware.....	2-1
Configuring the Hardware	2-2

Chapter 3

Hardware Overview

Analog Input	3-2
Input Mode	3-2
Input Range	3-3
Scanning Multiple Channels.....	3-4
Analog Output.....	3-5
Analog Output Glitch	3-5
Digital I/O.....	3-5
Timing Signal Routing.....	3-5
Programmable Function Inputs	3-7
Device and RTSI Clocks	3-7
RTSI Triggers.....	3-8

Chapter 4

Connecting Signals

I/O Connector	4-1
Analog Input Signal Overview	4-6
Types of Signal Sources	4-6
Floating Signal Sources	4-6
Ground-Referenced Signal Sources	4-7
Analog Input Modes	4-8
Connecting Analog Input Signals	4-9
Differential Connection Considerations (DIFF Input Mode)	4-11
Differential Connections for Nonreferenced or Floating Signal Sources	4-12
Differential Connections for Ground-Referenced Signal Sources ...	4-14
Single-Ended Connection Considerations	4-15
Single-Ended Connections for Floating Signal Sources (RSE Input Mode)	4-16
Single-Ended Connections for Grounded Signal Sources (NRSE Input Mode)	4-16
Common-Mode Signal Rejection Considerations	4-17
Connecting Analog Output Signals	4-17
Connecting Digital I/O Signals	4-19
Power Connections	4-20
Connecting Timing Signals	4-20
Programmable Function Input Connections	4-21
DAQ Timing Connections	4-22
TRIG1 Signal	4-23
TRIG2 Signal	4-24
STARTSCAN Signal	4-25
CONVERT* Signal	4-28
AIGATE Signal	4-29
SISOURCE Signal	4-29
SCANCLK Signal	4-30
EXTSTROBE* Signal	4-31
Waveform Generation Timing Connections	4-31
WFTRIG Signal	4-31
UPDATE* Signal	4-32
UISOURCE Signal	4-33
General-Purpose Timing Signal Connections	4-34
GPCTR0_SOURCE Signal	4-34
GPCTR0_GATE Signal	4-35
GPCTR0_OUT Signal	4-36
GPCTR0_UP_DOWN Signal	4-36
GPCTR1_SOURCE Signal	4-37

GPCTR1_GATE Signal	4-37
GPCTR1_OUT Signal	4-38
GPCTR1_UP_DOWN Signal	4-39
FREQ_OUT Signal	4-40
Field Wiring Considerations	4-40

Chapter 5 Calibration

Loading Calibration Constants	5-1
Self-Calibration.....	5-2
External Calibration	5-2
Other Considerations	5-3

Appendix A Specifications

Appendix B Custom Cabling and Optional Connectors

Appendix C Common Questions

Appendix D Technical Support and Professional Services

Glossary

Index



About This Manual

The NI 6034E/6035E/6036E is a high-performance multifunction analog, digital, and timing I/O device for PCI and PCMCIA computers. Supported functions include analog input (AI), analog output (AO), digital I/O (DIO), and timing I/O (TIO).

This manual describes the electrical and mechanical aspects of the NI 6034E/6035E/6036E and contains information concerning their operation and programming.

Conventions Used in This Manual

The following conventions are used in this manual:

- <> Angle brackets containing numbers separated by an ellipsis represent a range of values associated with a bit or signal name—for example, DIO<3..0>. Angle brackets can also denote a variable in a channel name—for example, ACH<*i*> and ACH<*i* + 8>.
- ◆ The ◆ symbol indicates that the text following it applies only to a specific product, a specific operating system, or a specific software version.
- » The » symbol leads you through nested menu items and dialog box options to a final action. The sequence **File»Page Setup»Options** directs you to pull down the **File** menu, select the **Page Setup** item, and select **Options** from the last dialog box.
-  This icon denotes a note, which alerts you to important information.
-  This icon denotes a caution, which advises you of precautions to take to avoid injury, data loss, or a system crash. When this symbol is marked on the product, see the [Safety Information](#) section of Chapter 1, [Introduction](#), for precautions to take.
- bold** Bold text denotes items that you must select or click in the software, such as menu items and dialog box options. Bold text also denotes parameter names and hardware labels.
- italic* Italic text denotes variables, emphasis, a cross reference, or an introduction to a key concept. This font also denotes text that is a placeholder for a word or value that you must supply.

monospace	Text in this font denotes text or characters that you should enter from the keyboard, sections of code, programming examples, and syntax examples. This font is also used for the proper names of disk drives, paths, directories, programs, subprograms, subroutines, device names, functions, operations, variables, filenames and extensions, and code excerpts.
NI-DAQ	NI-DAQ refers to the NI-DAQ driver software for PC compatible computers unless otherwise noted.
PC	PC refers to all PC AT series computers with PCI bus unless otherwise noted.
PCMCIA	PCMCIA is an international standards body and trade association that promotes the inter operability of PC cards.
Platform	Text in this font denotes a specific platform and indicates that the text following it applies only to that platform.

Related Documentation

The following documents contain information you may find helpful:

- *DAQ Quick Start Guide*
- *DAQ-STC Technical Reference Manual*
- *Measurement and Automation Explorer Help for DAQ*, which you can access by selecting **Start»Programs»National Instruments»Measurement and Automation»Help»Help Topics»NI-DAQ**
- NI Developer Zone tutorial, *Field Wiring and Noise Considerations for Analog Signals*, located at ni.com/zone
- *NI-DAQ Function Reference Manual*
- *NI-DAQ Online Help*
- *NI-DAQ User Manual for PC Compatibles*
- *PCI Local Bus Specification Revision 2.2*
- *PC Card Standard Release 7.1*

Introduction

This chapter describes the NI 6034E/6035E/6036E, lists what you need to get started, describes the optional software and equipment, and explains how to unpack the device.

About the NI 6034E/6035E/6036E

Thank you for buying the NI 6034E/6035E/6036E. The NI 6034E features 16 channels (eight differential) of 16-bit analog input, a 68-pin connector, and eight lines of DIO. The NI 6035E is identical to the NI 6034E, except that it has two channels of 12-bit analog output. The NI 6036E has the same features as the NI 6035E, except that the analog output is 16 bit instead of 12 bit.

The NI 6034E/6035E/6036E uses the NI data acquisition system timing controller (DAQ-STC) for time-related functions. The DAQ-STC consists of three timing groups that control AI, AO, and general-purpose counter/timer functions. These groups include a total of seven 24-bit and three 16-bit counters and a maximum timing resolution of 50 ns. The DAQ-STC makes possible applications such as buffered pulse generation, equivalent time sampling, and seamless changing of the sampling rate.

The NI 6034E/6035E/6036E uses the Real-Time System Integration (RTSI) bus to easily synchronize several measurement functions to a common trigger or timing event. In a PCI system, the RTSI bus consists of the NI RTSI bus interface and a ribbon cable to route timing and trigger signals between several functions on as many as five data acquisition (DAQ) devices in your computer.

The NI 6034E/6035E/6036E can interface to an SCXI system—the instrumentation front end for plug-in DAQ devices—so that you can acquire analog signals from thermocouples, resistance temperature detectors (RTDs), strain gauges, voltage sources, and current sources. You can also acquire or generate digital signals for communication and control.

The DAQCard-6036E is a low-power AI, AO, DIO, and TIO card for computers equipped with a Type II PC Card slot. The low power consumption of the DAQCard-6036E makes this card ideal for use in portable computers and makes portable data acquisition practical.

What You Need to Get Started

To set up and use the NI 6034E/6035E/6036E, you need the following:

- At least one of the following devices:
 - PCI-6034E
 - PCI-6035E
 - PCI-6036E
 - DAQCard-6036E
- NI 6034E/6035E/6036E User Manual*
- NI-DAQ software (**Windows or Mac OS**¹)
- One of the following software packages and documentation (Optional):
 - LabVIEW (**Windows or Mac OS**²)
 - Measurement Studio (**Windows**)
 - VI Logger (**Windows**)
- A computer

Software Programming Choices

When programming your National Instruments DAQ hardware, you can use NI application development environment (ADE) software or other ADEs. In either case, you use NI-DAQ.

NI-DAQ

NI-DAQ, which ships with the NI 6034E/6035E/6036E, has an extensive library of functions that you can call from the ADE. These functions allow you to use all the features of the NI 6034E/6035E/6036E.

¹ The PCI-6036E, DAQCard-6036E does *not* support NI-DAQ for Mac OS.

² The PCI-6036E, DAQCard-6036E does *not* support LabVIEW for Mac OS.

NI-DAQ carries out many of the complex interactions between the computer and the hardware. NI-DAQ maintains a consistent software interface among its different versions, so you can change platforms with minimal modifications to your code. Whether you use LabVIEW, Measurement Studio, VI Logger or other ADEs, your application uses NI-DAQ, as illustrated in Figure 1-1.

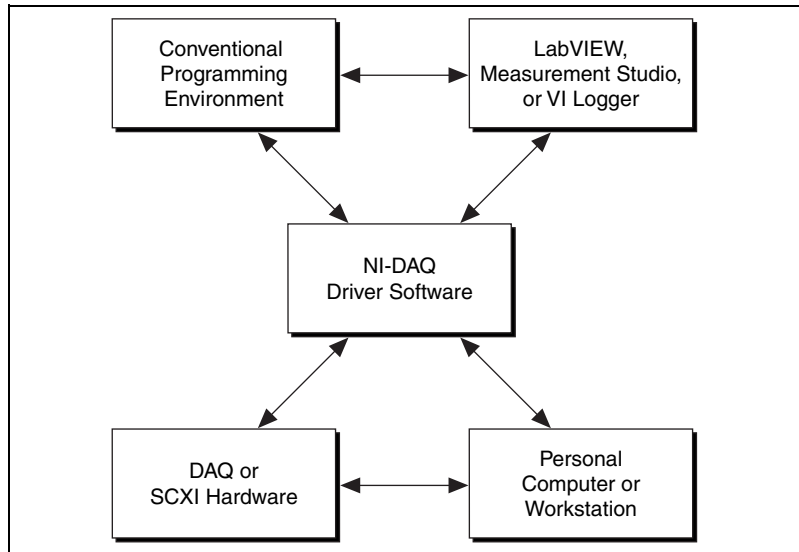

Figure 1-1. The Relationship Among the Programming Environment, NI-DAQ, and the Hardware

To download a free copy of the most recent version of NI-DAQ, click **Download Software** at ni.com.

National Instruments ADE Software

LabVIEW features interactive graphics, a state-of-the-art interface, and a powerful graphical programming language. The LabVIEW Data Acquisition VI Library, a series of virtual instruments (VIs) for using LabVIEW with National Instruments DAQ hardware, is included with LabVIEW.

Measurement Studio, which includes LabWindows/CVI, tools for Visual Basic, and tools for Visual C++, is a development suite that allows you to use ANSI C, Visual C++, and Visual Basic to design your test and measurement software. For C developers, Measurement Studio includes LabWindows/CVI, a fully integrated ANSI C application development environment that features interactive graphics and the LabWindows/CVI

Data Acquisition and Easy I/O libraries. For Visual Basic developers, Measurement Studio features a set of ActiveX controls for using National Instruments DAQ hardware. These ActiveX controls provide a high-level programming interface for building virtual instruments. For Visual C++ developers, Measurement Studio offers a set of Visual C++ classes and tools to integrate those classes into Visual C++ applications. The libraries, ActiveX controls, and classes are available with Measurement Studio and NI-DAQ.

VI Logger is an easy-to-use yet flexible tool specifically designed for data logging applications. Using dialog windows, you can configure data logging tasks to easily acquire, log, view, and share your data. VI Logger does not require any programming; it is a stand-alone, configuration-based software.

Using LabVIEW, Measurement Studio, or VI Logger greatly reduces the development time for your data acquisition and control application.

Optional Equipment

NI offers a variety of products to use with your device, including cables, connector blocks, and other accessories, as follows:

- Cables and cable assemblies, shielded and ribbon
- Connector blocks, shielded and unshielded screw terminals
- RTSI bus cables (PCI only)
- SCXI modules and accessories for isolating, amplifying, exciting, and multiplexing signals for relays and analog output; with SCXI, you can condition and acquire up to 3,072 channels
- Low-channel-count signal conditioning modules, devices, and accessories, including conditioning for strain gauges and RTDs, simultaneous sample and hold, and relays

For more information about these products, refer to ni.com/catalog or call the sales office nearest you.

Unpacking

The NI 6034E/6035E/6036E is shipped in an antistatic package to prevent electrostatic damage to the device. Electrostatic discharge (ESD) can damage several components on the device.



Caution *Never* touch the exposed pins of connectors.

To avoid such damage in handling the device, take the following precautions:

- Ground yourself using a grounding strap or by holding a grounded object.
- Touch the antistatic package to a metal part of your computer chassis before removing the device from the package.

Remove the device from the package and inspect the device for loose components or any sign of damage. Notify NI if the device appears damaged in any way. Do *not* install a damaged device into your computer.

Store the NI 6034E/6035E/6036E in the antistatic envelope when not in use.

Safety Information

The following section contains important safety information that you *must* follow when installing and using the product.

Do *not* operate the product in a manner not specified in this document. Misuse of the product can result in a hazard. You can compromise the safety protection built into the product if the product is damaged in any way. If the product is damaged, return it to National Instruments for repair.

Do *not* substitute parts or modify the product except as described in this document. Use the product only with the chassis, modules, accessories, and cables specified in the installation instructions. You *must* have all covers and filler panels installed during operation of the product.

Do *not* operate the product in an explosive atmosphere or where there may be flammable gases or fumes. Operate the product only at or below the pollution degree stated in Appendix A, *Specifications*. Pollution is foreign matter in a solid, liquid, or gaseous state that can reduce dielectric strength or surface resistivity. The following is a description of pollution degrees:

- Pollution degree 1 means no pollution or only dry, nonconductive pollution occurs. The pollution has no influence.
- Pollution degree 2 means that only nonconductive pollution occurs in most cases. Occasionally, however, a temporary conductivity caused by condensation must be expected.
- Pollution degree 3 means that conductive pollution occurs, or dry, nonconductive pollution occurs that becomes conductive due to condensation.

Clean the product with a soft nonmetallic brush. Make sure that the product is completely dry and free from contaminants before returning it to service.

You *must* insulate signal connections for the maximum voltage for which the product is rated. Do *not* exceed the maximum ratings for the product. Remove power from signal lines before connecting them to or disconnecting them from the product.

Operate this product only at or below the installation category stated in Appendix A, *Specifications*.

The following is a description of installation categories:

- Installation Category I is for measurements performed on circuits not directly connected to MAINS¹. This category is a signal level such as voltages on a printed wire board (PWB) on the secondary of an isolation transformer.

Examples of Installation Category I are measurements on circuits not derived from MAINS and specially protected (internal) MAINS-derived circuits.

- Installation Category II is for measurements performed on circuits directly connected to the low-voltage installation. This category refers to local-level distribution such as that provided by a standard wall outlet.

Examples of Installation Category II are measurements on household appliances, portable tools, and similar equipment.

¹ MAINS is defined as the electricity supply system to which the equipment concerned is designed to be connected either for powering the equipment or for measurement purposes.

- Installation Category III is for measurements performed in the building installation. This category is a distribution level referring to hardwired equipment that does not rely on standard building insulation.

Examples of Installation Category III include measurements on distribution circuits and circuit breakers. Other examples of Installation Category III are wiring including cables, bus-bars, junction boxes, switches, socket outlets in the building/fixed installation, and equipment for industrial use, such as stationary motors with a permanent connection to the building/fixed installation.

- Installation Category IV is for measurements performed at the source of the low-voltage (<1,000 V) installation.

Examples of Installation Category IV are electric meters, and measurements on primary overcurrent protection devices and ripple-control units.

Below is a diagram of a sample installation.

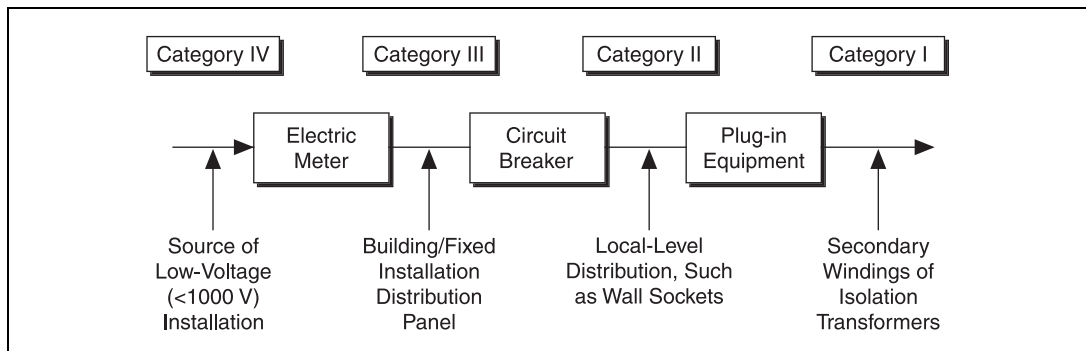

Installing and Configuring the NI 6034E/6035E/6036E

This chapter explains how to install and configure the NI 6034E/6035E/6036E.

Installing the Software

Complete the following steps to install the software before installing the NI 6034E/6035E/6036E.

1. Install the ADE, such as LabVIEW or Measurement Studio, according to the instructions on the CD and the release notes.
2. Install NI-DAQ according to the instructions on the CD.



Note It is important to install NI-DAQ before installing the NI 6034E/6035E/6036E to ensure that the device is properly detected.

Installing the Hardware

The NI 6034E/6035E/6036E fits in any PCI system expansion slot in the computer. The following are general installation instructions, so consult the computer user manual or technical reference manual for specific instructions and warnings.



Note Follow the guidelines in the computer documentation for installing plug-in hardware.

- ◆ PCI-6034E/6035E/6036E
 1. Power off and unplug the computer.
 2. Remove the cover.
 3. Make sure there are no lighted LEDs on the motherboard. If any are lit, wait until they go out before continuing the installation.
 4. Remove the expansion slot cover on the back panel of the computer.

5. Ground yourself using a grounding strap or by holding a grounded object. Follow the ESD protection precautions described in the [Unpacking](#) section of Chapter 1, [Introduction](#).
6. Insert the NI PCI-6034E/6035E/6036E into a PCI system slot. Gently rock the device to ease it into place. It may be a tight fit, but do *not* force the device into place. For optimal noise performance, leave as much room as possible between the NI PCI-6034E/6035E/6036E and other devices.
7. If required, screw the mounting bracket of the device to the back panel rail of the computer.
8. Replace the cover.
9. Plug in and power on the computer.



Note For proper cooling, all covers and filler panels must be installed.

The NI PCI-6034E/6035E/6036E is now installed.

◆ DAQCard-6036E installation

Insert the DAQCard into any available Type II PCMCIA slot until the connector is firmly seated. Insert the card face-up. It is keyed so that you can insert it only one way.

The DAQCard-6036E is now installed.

You are now ready to configure the hardware and software.

Configuring the Hardware

Thanks to the NI standard architecture for data acquisition, the PCI bus specification, and the PCMCIA (PC Card) specification, the NI 6034E/6035E/6036E is completely software configurable. Two types of configuration are performed on the NI 6034E/6035E/6036E: bus-related and data acquisition-related configuration.

The NI PCI-6034E/6035E/6036E is fully compatible with the industry-standard *PCI Local Bus Specification Revision 2.2*. This compatibility allows the PCI system to automatically perform all bus-related configurations, which include setting the base memory address and interrupt channel.

Data acquisition-related configuration, which you must perform, includes such settings as analog input coupling and range, and others. You can modify these settings using NI-DAQ or ADE software, such as LabVIEW and Measurement Studio. Refer to the software documentation for configuration instructions. Refer to Chapter 3, [Hardware Overview](#), for more information about the various settings available for the NI 6034E/6035E/6036E.

To configure the NI 6034E/6035E/6036E in Measurement & Automation Explorer (MAX), refer to ni.com/manuals to view either the *DAQ Quick Start Guide* or the *NI-DAQ User Manual for PC Compatibles*, or launch MAX to access the *Measurement and Automation Explorer Help for DAQ* at **Help»Help Topics»NI-DAQ**.

Hardware Overview

This chapter presents an overview of the hardware functions on the NI 6034E/6035E/6036E.

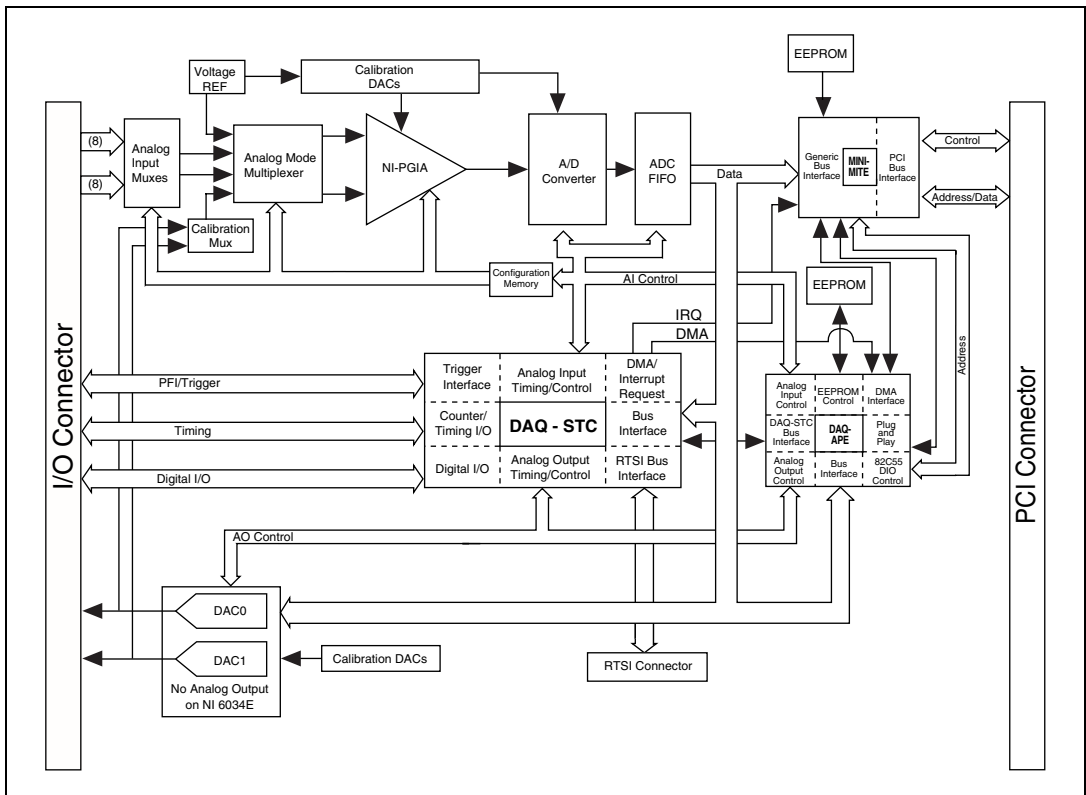

Figure 3-1. NI PCI-6034E/6035E/6036E Block Diagram

Figure 3-2 shows the block diagram for the DAQCard-6036E.

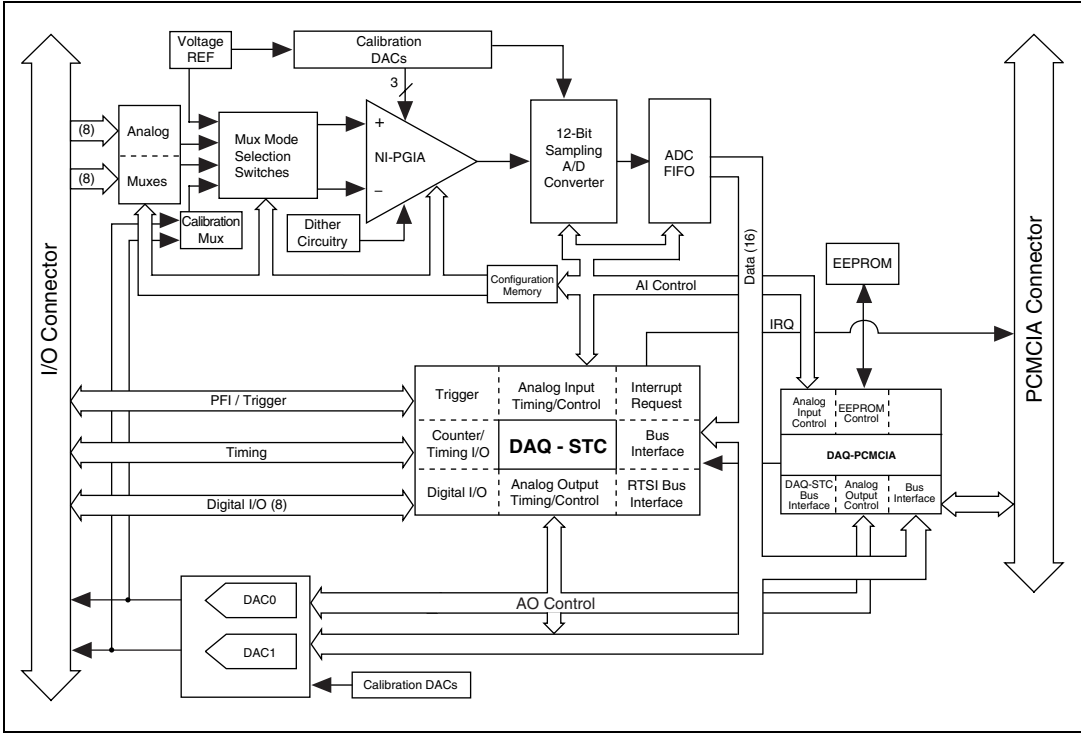

Figure 3-2. DAQCard-6036E Block Diagram

Analog Input

The AI section of the NI 6034E/6035E/6036E is software configurable. The following sections describe each AI setting.

Input Mode

The NI 6034E/6035E/6036E has three input modes—nonreferenced single-ended (NRSE) input, referenced single-ended (RSE) input, and differential (DIFF) input. The single-ended input configurations provide up to 16 channels. The DIFF input configuration provides up to eight channels. Input modes are programmed on a per channel basis for multimode scanning. For example, you can configure the circuitry to scan 12 channels—four differentially-configured channels and eight single-ended channels. Table 3-1 describes the three input configurations.

Table 3-1. Available Input Configurations

Configuration	Description
NRSE	A channel configured in NRSE mode uses one analog input line, which connects to the positive input of the programmable gain instrumentation amplifier (PGIA). The negative input of the PGIA connects to analog input sense (AISENSE).
RSE	A channel configured in RSE mode uses one analog input line, which connects to the positive input of the PGIA. The negative input of the PGIA is internally tied to analog input ground (AIGND).
DIFF	A channel configured in DIFF mode uses two analog input lines. One line connects to the positive input of the PGIA on the device, and the other connects to the negative input of the PGIA.

For diagrams showing the signal paths of the three configurations, refer to the [Connecting Analog Input Signals](#) section of Chapter 4, [Connecting Signals](#).

Input Range

The NI 6034E/6035E/6036E has a bipolar input range that changes with the programmed gain. Each channel may be programmed with a unique gain of 0.5, 1.0, 10, or 100, each corresponding to a different input voltage range. For best results, match the input range as closely as possible to the expected range of the input signal. Table 3-2 shows the input range and precision according to the gain used.

Table 3-2. Measurement Precision

Gain	Input Range	Precision*
0.5	-10 to +10 V	305.2 μ V
1.0	-5 to +5 V	152.6 μ V
10.0	-500 to +500 mV	15.3 μ V
100.0	-50 to +50 mV	1.53 μ V

* The value of 1 least significant bit (LSB) of the 16-bit ADC; that is, the voltage increment corresponding to a change of one count in the ADC 16-bit count.

Note: Refer to Appendix A, [Specifications](#), for absolute maximum ratings.

Scanning Multiple Channels

The devices can scan multiple channels at the same maximum rate as their single-channel rate; however, pay careful attention to the settling times for each device. No extra settling time is necessary between channels as long as the gain is constant and source impedances are low. Refer to Appendix A, *Specifications*, for a complete listing of settling times for each device.

When scanning among channels at various gains, the settling times may increase. When the PGIA switches to a higher gain, the signal on the previous channel may be well outside the new, smaller range. For instance, suppose a 4 V signal is connected to channel 0 and a 1 mV signal is connected to channel 1, and suppose the PGIA is programmed to apply a gain of one to channel 0 and a gain of 100 to channel 1. When the multiplexer switches to channel 1 and the PGIA switches to a gain of 100, the new full-scale range is ± 50 mV.

The approximately 4 V step from 4 V to 1 mV is 4,000% of the new full-scale range. It may take as long as 100 μ s for the circuitry to settle to 1 LSB after such a large transition. In general, this extra settling time is not needed when the PGIA is switching to a lower gain.

Settling times can also increase when scanning high-impedance signals because of a phenomenon called *charge injection*, where the AI multiplexer injects a small amount of charge into each signal source when that source is selected. If the impedance of the source is not low enough, the effect of the charge—a voltage error—will not have decayed by the time the ADC samples the signal. For this reason, keep source impedances under 1 k Ω to perform high-speed scanning.

Because of the limitations of settling times resulting from these conditions, multiple-channel scanning is not recommended unless sampling rates are low enough or it is necessary to sample several signals nearly simultaneously. The data is much more accurate and channel-to-channel independent if you acquire data from each channel separately (for example, 100 points from channel 0, then 100 points from channel 1, then 100 points from channel 2, and so on).

Analog Output

- ◆ NI 6035E and NI 6036E only

The NI 6035E supplies two channels of 12-bit AO voltage at the I/O connector, and the NI 6036E supplies two channels of 16-bit AO voltage at the I/O connector. Each device has a fixed bipolar output range of ± 10 V. Data written to the D/A converter (DAC) is interpreted in two's complement mode. In this mode, data values written to the AO channel can be either positive or negative. If you select unipolar range, data is interpreted in straight binary format. In straight binary mode, data values written to the AO channel range must be positive.

Analog Output Glitch

In normal operation, a DAC output glitches whenever it is updated with a new value. The glitch energy differs from code to code and appears as distortion in the frequency spectrum.

Digital I/O

The NI 6034E/6035E/6036E contains eight lines of DIO (DIO<0..7>) for general-purpose use. You can individually software configure each line for either input or output. At system startup and reset, the DIO ports are all high-impedance.

The hardware up/down control for general-purpose counters 0 and 1 are connected onboard to DIO6 and DIO7, respectively. Thus, you can use DIO6 and DIO7 to control the counters. The up/down control signals, GPCTR0_UP_DOWN and GPCTR1_UP_DOWN, are input only and do not affect the operation of the DIO lines.

Timing Signal Routing

The DAQ-STC chip provides a flexible interface for connecting timing signals to other devices or external circuitry. The NI 6034E/6035E/6036E uses the RTSI bus to interconnect timing signals between devices and the programmable function input (PFI) pins on the I/O connector to connect the device to external circuitry. These connections are designed to enable the NI 6034E/6035E/6036E to both control and be controlled by other devices and circuits.

The DAQ-STC has a total of 13 internal timing signals that you can control with an external source. Signals generated internally to the DAQ-STC can also control these timing signals, and these selections are fully software configurable. Figure 3-3 shows an example of the signal routing multiplexer controlling the CONVERT* signal.

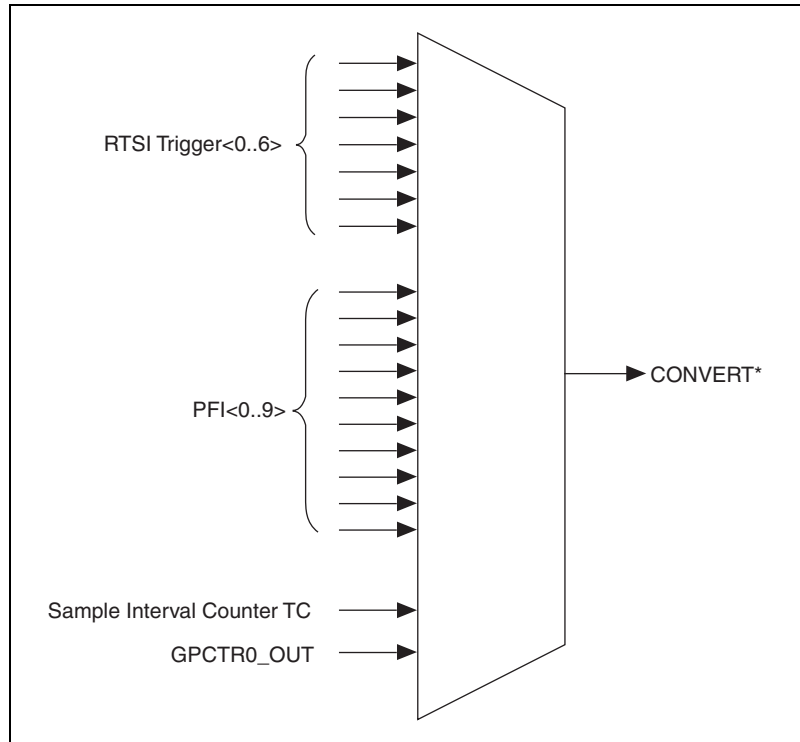

Figure 3-3. CONVERT* Signal Routing

Figure 3-3 shows that CONVERT* can be generated from a number of sources, including the external signals RTSI<0..6> and PFI<0..9> and the internal signals Sample Interval Counter TC and GPCTR0_OUT.

Many of these timing signals are also available as outputs on the RTSI pins, as indicated in the *RTSI Triggers* section, and on the PFI pins, as indicated in the *Programmable Function Input Connections* section of Chapter 4, *Connecting Signals*.

Programmable Function Inputs

The 10 PFI pins are connected to the signal routing multiplexer for each timing signal, and software can select any PFI pin as the external source for a given timing signal. It is important to note that any PFI pin can be used as an input by any timing signal and that multiple timing signals can simultaneously use the same PFI. This flexible routing scheme reduces the need to change physical connections to the I/O connector for different applications.

To use PFI pins as outputs, you must use the Route Signal VI to individually enable each PFI pin to output a specific internal timing signal. For example, if you need the UPDATE* signal as an output on the I/O connector, software must turn on the output driver for the PFI5/UPDATE* pin.

Device and RTSI Clocks

- ◆ NI PCI-6034E/6035E/6036E

Many functions performed by the NI 6034E/6035E/6036E require a frequency timebase to generate the necessary timing signals for controlling A/D conversions, DAC updates, or general-purpose signals at the I/O connector.

The NI 6034E/6035E/6036E can use either its internal 20 MHz timebase or a timebase received over the RTSI bus. In addition, if you configure the device to use the internal timebase, you can also program the device to drive its internal timebase over the RTSI bus to another device that is programmed to receive this timebase signal. This clock source, whether local or from the RTSI bus, is used directly by the device as the primary frequency source. The default configuration is to use the internal timebase without driving the RTSI bus timebase signal. This timebase is software selectable.

RTSI Triggers

The seven RTSI trigger lines on the RTSI bus provide a flexible connection scheme for devices sharing the RTSI bus. These bidirectional lines can drive any of eight timing signals onto the RTSI bus and can receive any of these timing signals. This connection scheme is shown in Figure 3-4 for the PCI-6034E/6035E/6036E.

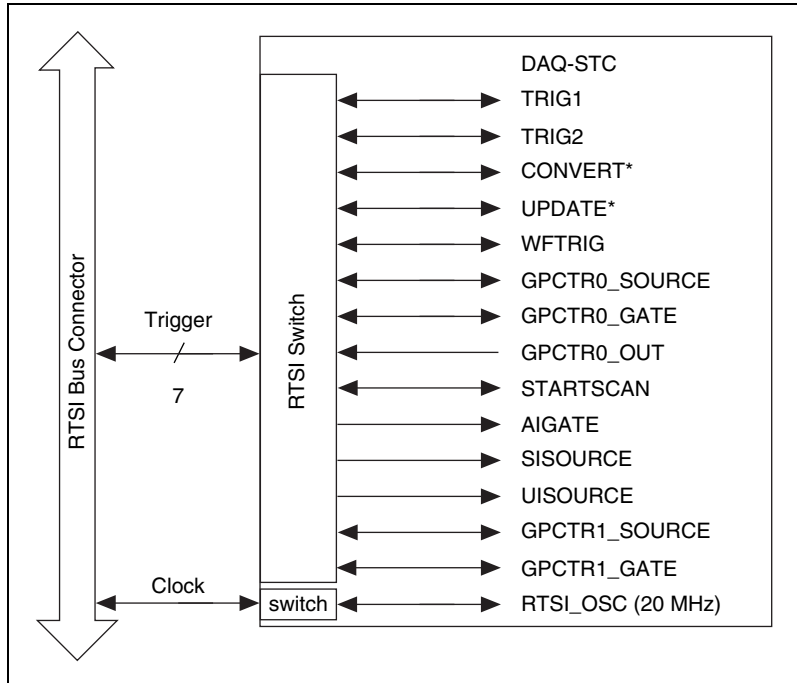

Figure 3-4. PCI RTSI Bus Signal Connection

Refer to the [Connecting Timing Signals](#) section of Chapter 4, [Connecting Signals](#), for a description of the signals shown in Figure 3-4.

Connecting Signals

This chapter describes how to make input and output signal connections to the NI 6034E/6035E/6036E using the I/O connector.

Table 4-1. I/O Connector Details

Device with I/O Connector	Number of Pins	Cable for Connecting to 100-pin Accessories	Cable for Connecting to 68-pin Accessories	Cable for Connecting to 50-pin Signal Accessories
NI-6034E, NI-6035E, NI-6036E	68	N/A	SH6868 Shielded Cable, R6868 Ribbon Cable	SH6850 Shielded Cable, R6850 Ribbon Cable
DAQCard-6036E	68	N/A	SHC68-68EP Shielded Cable, RC68-68 Ribbon Cable	68M-50F Adapter when used with the SHC68-68EP or RC68-68

I/O Connector

Figure 4-1 shows the pin assignments for the 68-pin I/O connector. Refer to Appendix B, *Custom Cabling and Optional Connectors*, for pin assignments of each optional 50- and 68-pin connector. Signal descriptions follow Figure 4-1.



Caution Connections that exceed any of the maximum ratings of input or output signals on the NI 6034E/6035E/6036E can damage the device and the computer. NI is *not* liable for any damage resulting from such signal connections. The *Protection* column of Table 4-3 shows the maximum input ratings for each signal.

ACH8	34	68	ACH0
ACH1	33	67	AIGND
AIGND	32	66	ACH9
ACH10	31	65	ACH2
ACH3	30	64	AIGND
AIGND	29	63	ACH11
ACH4	28	62	AISENSE
AIGND	27	61	ACH12
ACH13	26	60	ACH5
ACH6	25	59	AIGND
AIGND	24	58	ACH14
ACH15	23	57	ACH7
DAC0OUT ¹	22	56	AIGND
DAC1OUT ¹	21	55	AOGND
RESERVED	20	54	AOGND
DIO4	19	53	DGND
DGND	18	52	DIO0
DIO1	17	51	DIO5
DIO6	16	50	DGND
DGND	15	49	DIO2
+5V	14	48	DIO7
DGND	13	47	DIO3
DGND	12	46	SCANCLK
PFI0/TRIG1	11	45	EXTSTROBE*
PFI1/TRIG2	10	44	DGND
DGND	9	43	PFI2/CONVERT*
+5V	8	42	PFI3/GPCTR1_SOURCE
DGND	7	41	PFI4/GPCTR1_GATE
PFI5/UPDATE*	6	40	GPCTR1_OUT
PFI6/WFTRIG	5	39	DGND
DGND	4	38	PFI7/STARTSCAN
PFI9/GPCTR0_GATE	3	37	PFI8/GPCTR0_SOURCE
GPCTR0_OUT	2	36	DGND
FREQ_OUT	1	35	DGND

¹ AO is not available on the NI 6034E.

Figure 4-1. I/O Connector Pin Assignment for the NI 6034E/6035E/6036E

Table 4-2. Signal Descriptions for I/O Connector Pins

Signal Name	Reference	Direction	Description
AIGND	—	—	Analog Input Ground—These pins are the reference point for single-ended measurements in RSE configuration and the bias current return point for differential measurements. All three ground references—AIGND, AOGND, and DGND—are connected together on the device.
ACH<0..15>	AIGND	Input	Analog Input Channels 0 through 15—Each channel pair, ACH< <i>i</i> , <i>i</i> +8> (<i>i</i> = 0..7), can be configured as either one differential input or two single-ended inputs.
AISENSE	AIGND	Input	Analog Input Sense—This pin serves as the reference node for any channel ACH<0..15> in NRSE configuration.
DAC0OUT ¹	AOGND	Output	Analog Channel 0 Output—This pin supplies the voltage output of analog output channel 0.
DAC1OUT ¹	AOGND	Output	Analog Channel 1 Output—This pin supplies the voltage output of analog output channel 1.
AOGND	—	—	Analog Output Ground—The analog output voltages are referenced to this node. All three ground references—AIGND, AOGND, and DGND—are connected together on the device.
DGND	—	—	Digital Ground—This pin supplies the reference for the digital signals at the I/O connector as well as the +5 VDC supply. All three ground references—AIGND, AOGND, and DGND—are connected together on the device.
DIO<0..7>	DGND	Input Output	Digital I/O Signals—DIO6 and 7 can control the up/down signal of general-purpose counters 0 and 1, respectively.
+5V	DGND	Output	+5 VDC Source—These pins are fused for up to 1 A of +5 V supply. The fuse is self resetting.
SCANCLK	DGND	Output	Scan Clock—This pin, when enabled, pulses once for each A/D conversion in scanning mode. The low-to-high edge indicates when the input signal can be removed from the input or switched to another signal.
EXTSTROBE*	DGND	Output	External Strobe—This output can be toggled under software control to latch signals or trigger events on external devices.
PFI0/TRIG1	DGND	Input Output	PFI0/Trigger 1—As an input, this signal is one of the PFIs. PFI signals are explained in the Connecting Timing Signals section. As an output, this signal is the TRIG1 (AI Start Trigger) signal. In posttrigger data acquisition sequences, a low-to-high transition indicates the initiation of the acquisition sequence. In pretrigger applications, a low-to-high transition indicates the initiation of the pretrigger conversions.

Table 4-2. Signal Descriptions for I/O Connector Pins (Continued)

Signal Name	Reference	Direction	Description
PFI1/TRIG2	DGND	Input Output	PFI1/Trigger 2—As an input, this signal is one of the PFIs. As an output, this signal is the TRIG2 (AI Stop Trigger) signal. In pretrigger applications, a low-to-high transition indicates the initiation of the posttrigger conversions. TRIG2 is not used in posttrigger applications.
PFI2/CONVERT*	DGND	Input Output	PFI2/Convert—As an input, this signal is one of the PFIs. As an output, this signal is the CONVERT* (AI Convert) signal. A high-to-low edge on CONVERT* indicates that an A/D conversion is occurring.
PFI3/GPCTR1_SOURCE	DGND	Input Output	PFI3/Counter 1 Source—As an input, this signal is one of the PFIs. As an output, this signal is the GPCTR1_SOURCE signal. This signal reflects the actual source connected to the general-purpose counter 1.
PFI4/GPCTR1_GATE	DGND	Input Output	PFI4/Counter 1 Gate—As an input, this signal is one of the PFIs. As an output, this signal is the GPCTR1_GATE signal. This signal reflects the actual gate signal connected to the general-purpose counter 1.
GPCTR1_OUT	DGND	Output	Counter 1 Output—This output is from the general-purpose counter 1 output.
PFI5/UPDATE*	DGND	Input Output	PFI5/Update—As an input, this signal is one of the PFIs. As an output, this signal is the UPDATE* (AO Update) signal. A high-to-low edge on UPDATE* indicates that the analog output primary group is being updated.
PFI6/WFTRIG	DGND	Input Output	PFI6/Waveform Trigger—As an input, this signal is one of the PFIs. As an output, this signal is the WFTRIG (AO Start Trigger) signal. In timed analog output sequences, a low-to-high transition indicates the initiation of the waveform generation.
PFI7/STARTSCAN	DGND	Input Output	PFI7/Start of Scan—As an input, this signal is one of the PFIs. As an output, this signal is the STARTSCAN (AI Scan Start) signal. This pin pulses once at the start of each analog input scan in the interval scan. A low-to-high transition indicates the start of the scan.
PFI8/GPCTR0_SOURCE	DGND	Input Output	PFI8/Counter 0 Source—As an input, this signal is one of the PFIs. As an output, this signal is the GPCTR0_SOURCE signal. This signal reflects the actual source connected to the general-purpose counter 0.
PFI9/GPCTR0_GATE	DGND	Input Output	PFI9/Counter 0 Gate—As an input, this signal is one of the PFIs. As an output, this signal is the GPCTR0_GATE signal. This signal reflects the actual gate signal connected to the general-purpose counter 0.

Table 4-2. Signal Descriptions for I/O Connector Pins (Continued)

Signal Name	Reference	Direction	Description
GPCTRO_OUT	DGND	Output	Counter 0 Output—This output is from the general-purpose counter 0 output.
FREQ_OUT	DGND	Output	Frequency Output—This output is from the frequency generator output.
* Indicates that the signal is active low.			
¹ Not available on the NI 6034E.			

Table 4-3. I/O Signal Summary for the NI 6034E/6035E/6036E

Signal Name	Signal Type and Direction	Impedance Input/ Output	Protection (Volts) On/Off	Source (mA at V)	Sink (mA at V)	Rise Time (ns)	Bias
ACH<0..15>	AI	100 G Ω in parallel with 100 pF	25/15	—	—	—	± 200 pA
AISENSE	AI	100 G Ω in parallel with 100 pF	25/15	—	—	—	± 200 pA
AIGND	AO	—	—	—	—	—	—
DAC0OUT (NI 6035E/6036E only)	AO	0.1 Ω	Short-circuit to ground	5 at 10	5 at -10	—	—
DAC1OUT (NI 6035E/6036E only)	AO	0.1 Ω	Short-circuit to ground	5 at 10	5 at -10	—	—
AOGND	AO	—	—	—	—	—	—
DGND	DO	—	—	—	—	—	—
V _{CC}	DO	0.1 Ω	Short-circuit to ground	1A fused	—	—	—
DIO<0..7>	DIO	—	V _{CC} +0.5	13 at (V _{CC} -0.4)	24 at 0.4	1.1	50 k Ω pu
SCANCLK	DO	—	—	3.5 at (V _{CC} -0.4)	5 at 0.4	1.5	50 k Ω pu
EXTSTROBE*	DO	—	—	3.5 at (V _{CC} -0.4)	5 at 0.4	1.5	50 k Ω pu
PFI0/TRIG1	DIO	—	V _{CC} +0.5	3.5 at (V _{CC} -0.4)	5 at 0.4	1.5	50 k Ω pu
PFI1/TRIG2	DIO	—	V _{CC} +0.5	3.5 at (V _{CC} -0.4)	5 at 0.4	1.5	50 k Ω pu

Table 4-3. I/O Signal Summary for the NI 6034E/6035E/6036E (Continued)

Signal Name	Signal Type and Direction	Impedance Input/ Output	Protection (Volts) On/Off	Source (mA at V)	Sink (mA at V)	Rise Time (ns)	Bias
PFI2/CONVERT*	DIO	—	$V_{CC} + 0.5$	3.5 at ($V_{CC} - 0.4$)	5 at 0.4	1.5	50 k Ω pu
PFI3/GPCTR1_SOURCE	DIO	—	$V_{CC} + 0.5$	3.5 at ($V_{CC} - 0.4$)	5 at 0.4	1.5	50 k Ω pu
PFI4/GPCTR1_GATE	DIO	—	$V_{CC} + 0.5$	3.5 at ($V_{CC} - 0.4$)	5 at 0.4	1.5	50 k Ω pu
GPCTR1_OUT	DO	—	—	3.5 at ($V_{CC} - 0.4$)	5 at 0.4	1.5	50 k Ω pu
PFI5/UPDATE*	DIO	—	$V_{CC} + 0.5$	3.5 at ($V_{CC} - 0.4$)	5 at 0.4	1.5	50 k Ω pu
PFI6/WFTRIG	DIO	—	$V_{CC} + 0.5$	3.5 at ($V_{CC} - 0.4$)	5 at 0.4	1.5	50 k Ω pu
PFI7/STARTSCAN	DIO	—	$V_{CC} + 0.5$	3.5 at ($V_{CC} - 0.4$)	5 at 0.4	1.5	50 k Ω pu
PFI8/GPCTR0_SOURCE	DIO	—	$V_{CC} + 0.5$	3.5 at ($V_{CC} - 0.4$)	5 at 0.4	1.5	50 k Ω pu
PFI9/GPCTR0_GATE	DIO	—	$V_{CC} + 0.5$	3.5 at ($V_{CC} - 0.4$)	5 at 0.4	1.5	50 k Ω pu
GPCTR0_OUT	DO	—	—	3.5 at ($V_{CC} - 0.4$)	5 at 0.4	1.5	50 k Ω pu
FREQ_OUT	DO	—	—	3.5 at ($V_{CC} - 0.4$)	5 at 0.4	1.5	50 k Ω pu
pu = pull up DO = Digital Output The tolerance on the 50 k Ω pull-up resistors is very large. Actual value may range between 17 and 100 k Ω .							

Analog Input Signal Overview

The AI signals for the NI 6034E/6035E/6036E are ACH<0..15>, ASENSE, and AIGND. How you connect these AI signals to the device depends on the type of input signal source and the configuration of the AI channels.

This section provides an overview of the types of signal sources and input modes. Specific signal connection information is provided in the [Connecting Analog Input Signals](#) section.

Types of Signal Sources

When making signal connections, you must first determine whether the signal sources are floating or ground referenced. The following sections describe these two signal types.

Floating Signal Sources

A floating signal source is not connected to the building ground system and instead has an isolated ground-reference point. Some examples of floating signal sources are outputs of transformers, thermocouples, battery-powered

devices, optical isolator outputs, and isolation amplifiers. An instrument or device that has an isolated output is a floating signal source. You must tie the ground reference of a floating signal to the NI 6034E/6035E/6036E AI ground to establish a local or onboard reference for the signal. Otherwise, the measured input signal varies as the source floats out of the common-mode input range.

Ground-Referenced Signal Sources

A ground-referenced signal source is connected in some way to the building system ground and is, therefore, already connected to a common ground point with respect to the NI 6034E/6035E/6036E, assuming that the computer is plugged into the same power system. Nonisolated outputs of instruments and devices that plug into the building power system fall into this category.

The difference in ground potential between two instruments connected to the same building power system is typically between 1 and 100 mV, but it can be much higher if power distribution circuits are not properly connected. If a grounded signal source is improperly measured, this difference may appear as a measurement error. The connection instructions for grounded signal sources are designed to eliminate this ground potential difference from the measured signal.

Analog Input Modes

You can configure the device for NRSE, RSE, or DIFF input mode. With the different modes, you can use the PGIA in different ways. Figure 4-2 shows a diagram of the device PGIA.

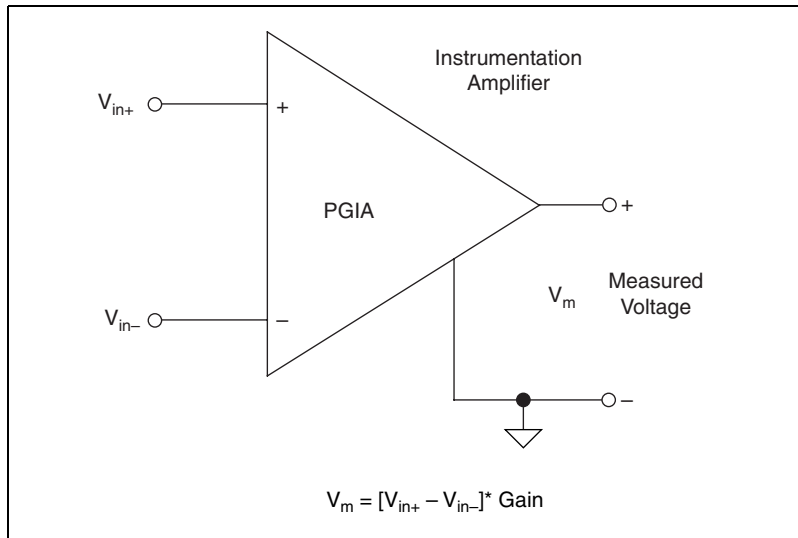

Figure 4-2. PGIA Diagram

In single-ended modes (RSE and NRSE), signals connected to ACH<0..15> are routed to the positive input of the PGIA. In DIFF mode, signals connected to ACH<0..7> are routed to the positive input of the PGIA, and signals connected to ACH<8..15> are routed to the negative input of the PGIA.



Caution Exceeding the differential and common-mode input ranges distorts the input signals. Exceeding the maximum input voltage rating can damage the device and the computer. NI is *not* liable for any damage resulting from such signal connections. The maximum input voltage ratings are listed in the *Protection* column of Table 4-3.

In NRSE mode, the AISENSE signal is connected internally to the negative input of the PGIA when the corresponding channels are selected. In DIFF and RSE modes, AISENSE is left unconnected.

AIGND is an AI common signal that is routed directly to the ground tie point on the devices. You can use this signal for a general analog ground tie point to the device if necessary.

The PGIA applies gain and common-mode voltage rejection and presents high-input impedance to the analog input signals connected to the device. Signals are routed to the positive and negative inputs of the PGIA through input multiplexers on the device. The PGIA converts two input signals to the measured voltage (V_m), which is the difference between the two input signals multiplied by the gain setting of the amplifier. The amplifier output voltage is referenced to the ground for the device. The ADC measures this output voltage when it performs A/D conversions.

You must reference all signals to ground either at the source device or at the device. If you have a floating source, you should reference the signal to ground by using the RSE input mode or the DIFF input configuration with bias resistors. To do so, refer to the [Differential Connections for Nonreferenced or Floating Signal Sources](#) section. If you have a grounded source, you should not reference the signal to AIGND. You can avoid this reference by using DIFF or NRSE input modes.

Connecting Analog Input Signals

The following sections discuss the use of single-ended and differential measurements and make recommendations for measuring both floating and ground-referenced signal sources.

Figure 4-3 summarizes the recommended input configuration for both types of signal sources.

Input	Signal Source Type	
	Floating Signal Source (Not Connected to Building Ground)	Grounded Signal Source
	<p>Examples</p> <ul style="list-style-type: none"> • Ungrounded Thermocouples • Signal Conditioning with Isolated Outputs • Battery Devices 	<p>Examples</p> <ul style="list-style-type: none"> • Plug-in Instruments with Nonisolated Outputs
Differential (DIFF)	<p>See text for information on bias resistors.</p>	
Single-Ended — Ground Referenced (RSE)		<p>NOT RECOMMENDED</p> <p>Ground-loop losses, V_g, are added to measured signal.</p>
Single-Ended — Nonreferenced (NRSE)	<p>See text for information on bias resistors.</p>	

Figure 4-3. Summary of Analog Input Connections

Differential Connection Considerations (DIFF Input Mode)

In DIFF input mode, the analog input signal has its own reference signal or signal return path. In DIFF mode, the analog input channels are paired, with ACH<*i*> as the signal input and ACH<*i*+8> as the signal reference. For example, ACH0 is paired with ACH8, and ACH1 is paired with ACH9. The input signal is tied to the positive input of the PGIA, and its reference signal, or return, is tied to the negative input of the PGIA.

You should use differential input connections for any channel that meets any of the following conditions:

- The input signal is low level (less than 1 V).
- The leads connecting the signal to the device are greater than 10 ft (3 m).
- The input signal requires a separate ground-reference point or return signal.
- The signal leads travel through noisy environments.

Differential signal connections reduce picked-up noise and increase common-mode noise rejection. Differential signal connections also allow input signals to float within the common-mode limits of the PGIA.

Differential Connections for Nonreferenced or Floating Signal Sources

Figure 4-4 shows how to connect a floating signal source to a channel configured in DIFF input mode on the NI 6034E/6035E/6036E.

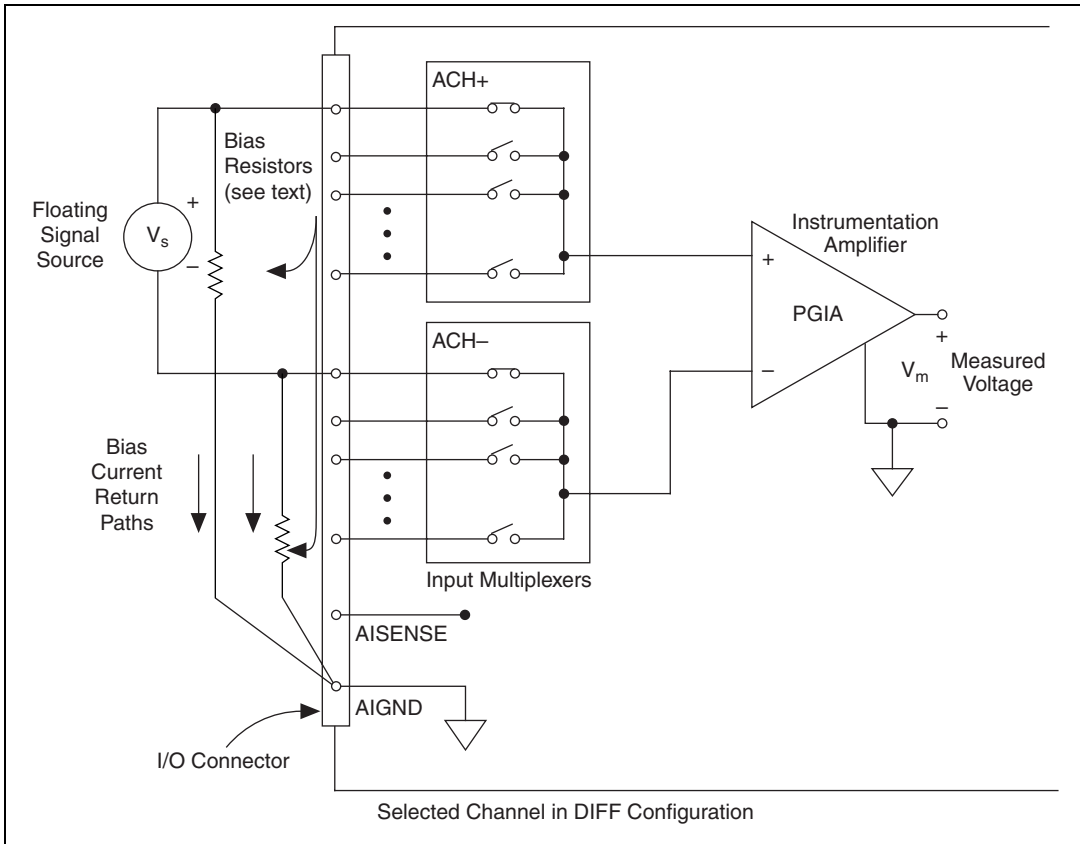

Figure 4-4. Differential Input Connections for Nonreferenced Signals

Figure 4-4 shows two bias resistors connected in parallel with the signal leads of a floating signal source. If you do not use the resistors and the source is truly floating, the source is not likely to remain within the common-mode signal range of the PGIA. The PGIA then saturates, causing erroneous readings.

In DIFF input mode, you must reference the source to AIGND. The easiest way is to connect the positive side of the signal to the positive input of the PGIA and connect the negative side of the signal to AIGND as well as to the negative input of the PGIA, without any resistors. This connection works well for DC-coupled sources with low source impedance (less than 100 Ω).

However, for larger source impedances, this connection leaves the differential signal path significantly out of balance. Noise that couples electrostatically onto the positive line does not couple onto the negative line because it is connected to ground. Hence, this noise appears as a differential-mode signal instead of a common-mode signal, and the PGIA does not reject it. In this case, instead of directly connecting the negative line to AIGND, connect it to AIGND through a resistor that is about 100 times the equivalent source impedance. The resistor puts the signal path nearly in balance so that about the same amount of noise couples onto both connections, yielding better rejection of electrostatically-coupled noise. Also, this configuration does not load down the source (other than the very high input impedance of the PGIA).

You can fully balance the signal path by connecting another resistor of the same value between the positive input and AIGND, as shown in Figure 4-4. This balanced configuration offers slightly better noise rejection but has the disadvantage of loading the source down with the series combination (sum) of the two resistors. If, for example, the source impedance is 2 k Ω and each of the two resistors is 100 k Ω , the resistors load down the source with 200 k Ω and produce a -1% gain error.

Both inputs of the PGIA require a DC path to ground in order for the PGIA to work. If the source is AC coupled (capacitively coupled), the PGIA needs a resistor between the positive input and AIGND. If the source has low impedance, choose a resistor that is large enough not to significantly load the source but small enough not to produce significant input offset voltage as a result of input bias current (typically 100 k Ω to 1 M Ω). In this case, you can tie the negative input directly to AIGND. If the source has high output impedance, you should balance the signal path as previously described using the same value resistor on both the positive and negative inputs. You should be aware that there is some gain error from loading down the source.

Differential Connections for Ground-Referenced Signal Sources

Figure 4-5 shows how to connect a ground-referenced signal source to a channel on the device configured in DIFF input mode.

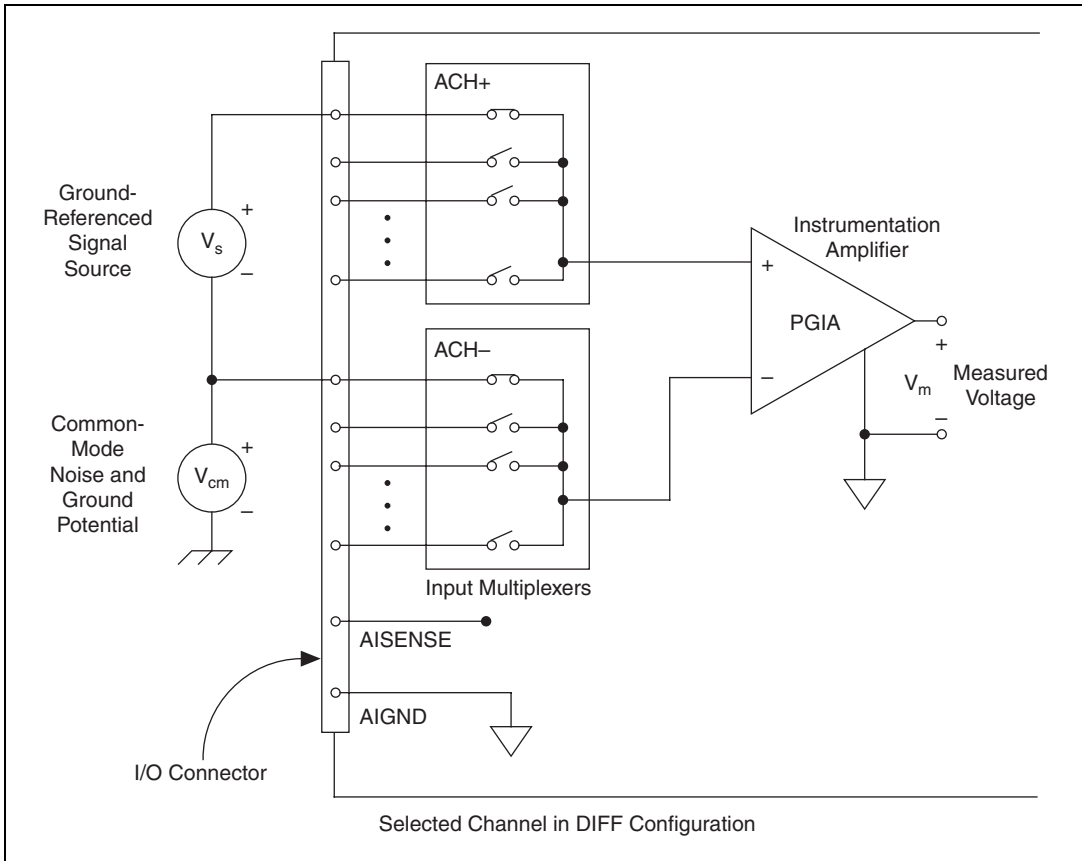

Figure 4-5. Differential Input Connections for Ground-Referenced Signals

With this type of connection, the PGIA rejects both the common-mode noise in the signal and the ground potential difference between the signal source (V_s) and the device ground (V_{cm}) in Figure 4-5.

Single-Ended Connection Considerations

A single-ended connection is one in which the AI signal of the NI 6034E/6035E/6036E is referenced to a ground that can be shared with other input signals. The input signal is tied to the positive input of the PGIA, and the ground is tied to the negative input of the PGIA.

When every channel is configured for single-ended input, up to 16 AI channels are available.

You can use single-ended input connections for any input signal that meets the following conditions:

- The input signal is high level (greater than 1 V).
- The leads connecting the signal to the device are less than 10 ft (3 m).
- The input signal can share a common reference point with other signals.

DIFF input connections are recommended for greater signal integrity for any input signal that does not meet the preceding conditions.

Using software, you can configure the channels for two different types of single-ended connections—RSE configuration and NRSE configuration. Use RSE input mode for floating signal sources; in this case, the device provides the reference ground point for the external signal. Use NRSE input mode for ground-referenced signal sources. In this case, the external signal supplies its own reference ground point, and the NI 6034E/6035E/6036E should not supply one.

In single-ended configurations, more electrostatic and magnetic noise couples into the signal connections than in differential configurations. The coupling is the result of differences in the signal path. Magnetic coupling is proportional to the area between the two signal conductors. Electrical coupling is a function of how much the electric field differs between the two conductors.

Single-Ended Connections for Floating Signal Sources (RSE Input Mode)

Figure 4-6 shows how to connect a floating signal source to a channel configured for RSE mode on the NI 6034E/6035E/6036E.

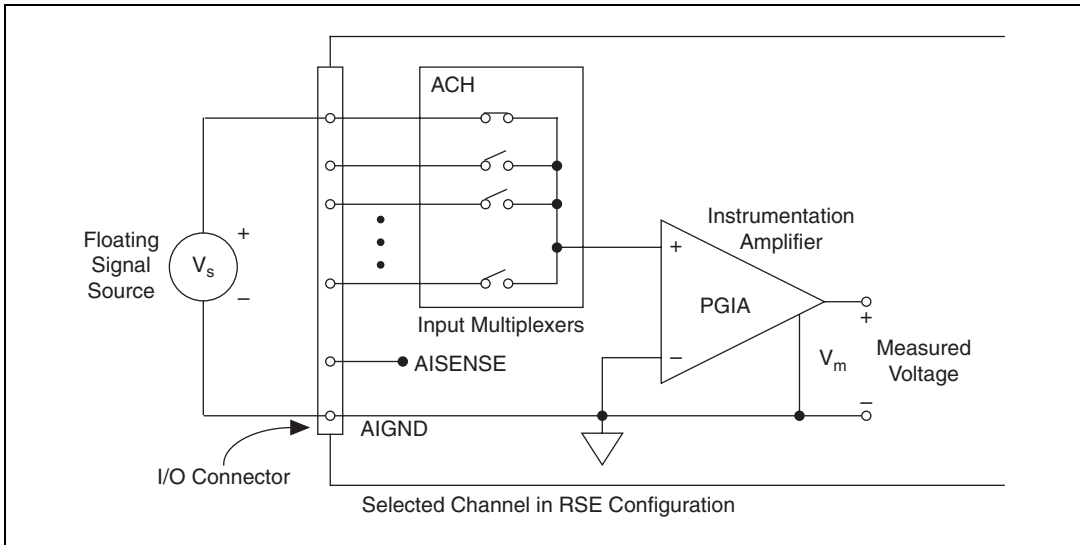

Figure 4-6. Single-Ended Input Connections for Nonreferenced or Floating Signals

Single-Ended Connections for Grounded Signal Sources (NRSE Input Mode)

To measure a grounded signal source with a single-ended configuration, configure the NI 6034E/6035E/6036E in the NRSE input mode. The signal is then connected to the positive input of the PGIA, and the signal local ground reference is connected to the negative input of the PGIA. The ground point of the signal should, therefore, be connected to the AISENSE pin. Any potential difference between the device ground and the signal ground appears as a common-mode signal at both the positive and negative inputs of the PGIA, and this difference is rejected by the amplifier. If the input circuitry of a device were referenced to ground in this situation as it is in the RSE input configuration, this difference in ground potentials would appear as an error in the measured voltage.

Figure 4-7 shows how to connect a grounded signal source to a channel configured for NRSE mode on the NI 6034E/6035E/6036E.

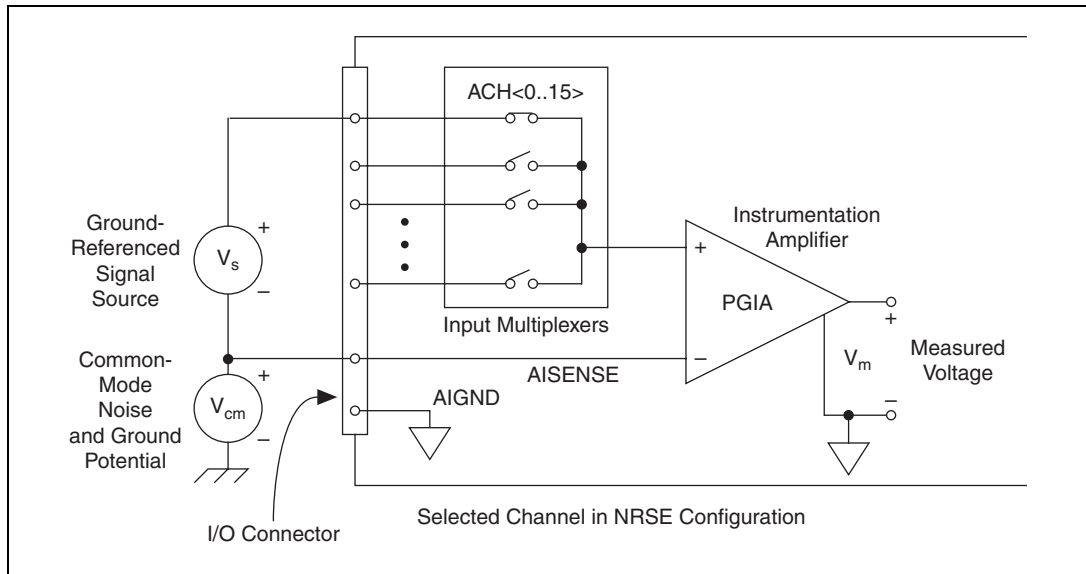

Figure 4-7. Single-Ended Input Connections for Ground-Referenced Signals

Common-Mode Signal Rejection Considerations

Figures 4-5 and 4-7 show connections for signal sources that are already referenced to some ground point with respect to the NI 6034E/6035E/6036E. In these cases, the PGIA can reject any voltage caused by ground potential differences between the signal source and the device. In addition, with differential input connections, the PGIA can reject common-mode noise pickup in the leads connecting the signal sources to the device. The PGIA can reject common-mode signals as long as V_{in+} and V_{in-} (input signals) are both within ± 11 V of AIGND.

Connecting Analog Output Signals

- ◆ NI 6035E and NI 6036E only

The AO signals are DAC0OUT, DAC1OUT, and AOGND. DAC0OUT and DAC1OUT are not available on the NI 6034E.

DAC0OUT is the voltage output signal for AO channel 0. DAC1OUT is the voltage output signal for AO channel 1.

AOGND is the ground-referenced signal for both AO channels and the external reference signal.

Figure 4-8 shows how to connect AO signals to the NI 6035E/6036E.

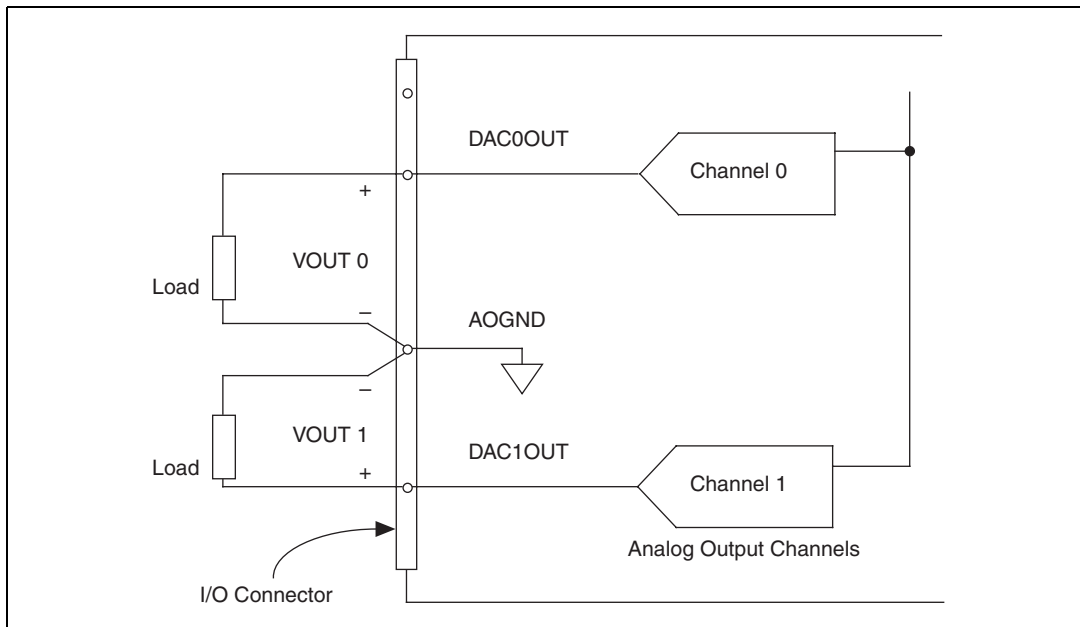

Figure 4-8. Analog Output Connections

Connecting Digital I/O Signals

The NI 6034E/6035E/6036E has DIO signals DIO<0..7> and DGND. DIO<0..7> are the signals making up the DIO port, and DGND is the ground-reference signal for the DIO port. You can program all lines individually to be inputs or outputs.



Caution Exceeding the maximum input voltage ratings, which are listed in Table 4-3, can damage the NI 6034E/6035E/6036E and the computer. NI is *not* liable for any damage resulting from such signal connections.

Figure 4-9 shows signal connections for three typical DIO applications.

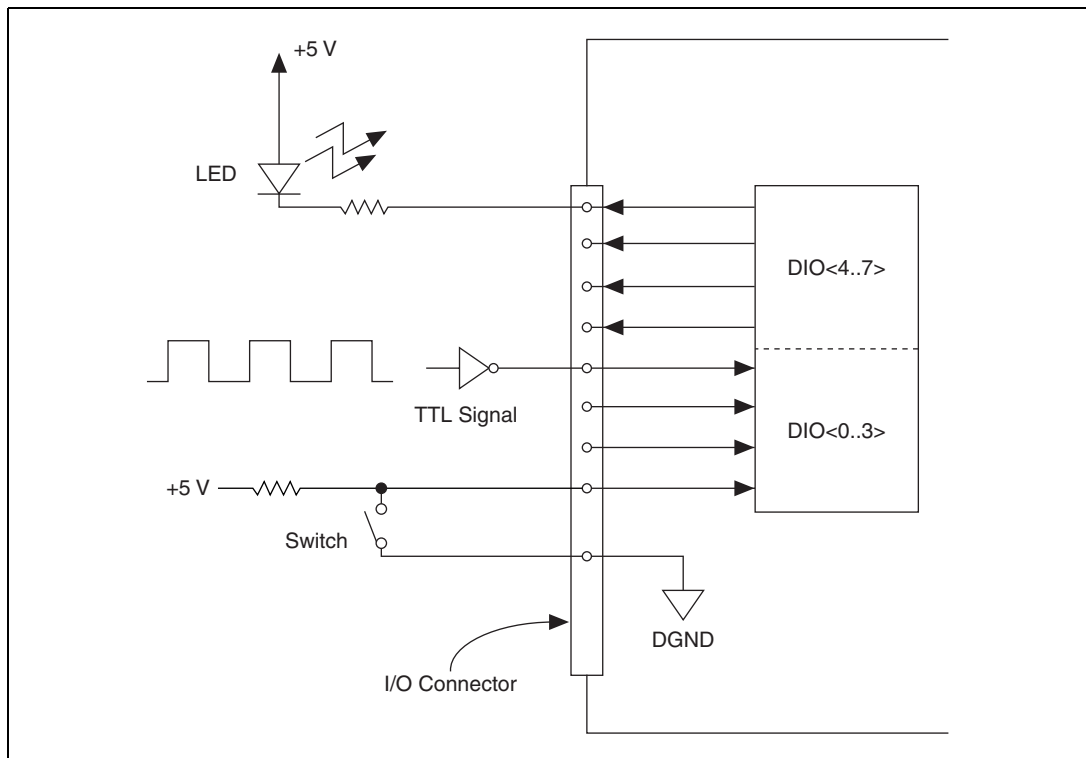

Figure 4-9. Digital I/O Connections

Figure 4-9 shows DIO<0..3> configured for digital input and DIO<4..7> configured for digital output. Digital input applications include receiving TTL signals and sensing external device states such as the switch state shown in Figure 4-9. Digital output applications include sending TTL signals and driving external devices such as the LED shown in Figure 4-9.

Power Connections

Two pins on the I/O connector supply +5 V from the computer power supply using a self-resetting fuse. The fuse resets automatically within a few seconds after the overcurrent condition is removed. These pins are referenced to DGND and can be used to power external digital circuitry. The power rating is +4.65 to +5.25 VDC at 1 A.



Caution Under no circumstances should you connect these +5 V power pins directly to analog or digital ground or to any other voltage source on the NI 6034E/6035E/6036E or any other device. Doing so can damage the NI 6034E/6035E/6036E and the computer. NI is *not* liable for damage resulting from such a connection.

Connecting Timing Signals



Caution Exceeding the maximum input voltage ratings, which are listed in Table 4-3, can damage the device and the computer. NI is *not* liable for any damage resulting from such signal connections.

All external control over the timing of the device is routed through the 10 PFIs labeled PFI<0..9>. These signals are explained in detail in the [Programmable Function Input Connections](#) section. These PFIs are bidirectional; as outputs they are not programmable and reflect the state of many DAQ, waveform generation, and general-purpose timing signals. There are five other dedicated outputs for the remainder of the timing signals. As inputs, the PFI signals are programmable and can control any DAQ, waveform generation, and general-purpose timing signals.

The DAQ signals are explained in the [DAQ Timing Connections](#) section. The [Waveform Generation Timing Connections](#) section explains the waveform generation signals, and the [General-Purpose Timing Signal Connections](#) section explains the general-purpose timing signals.

All digital timing connections are referenced to DGND. This reference is demonstrated in Figure 4-10, which shows how to connect an external TRIG1 source and an external CONVERT* source to two PFI pins on the NI 6034E/6035E/6036E.

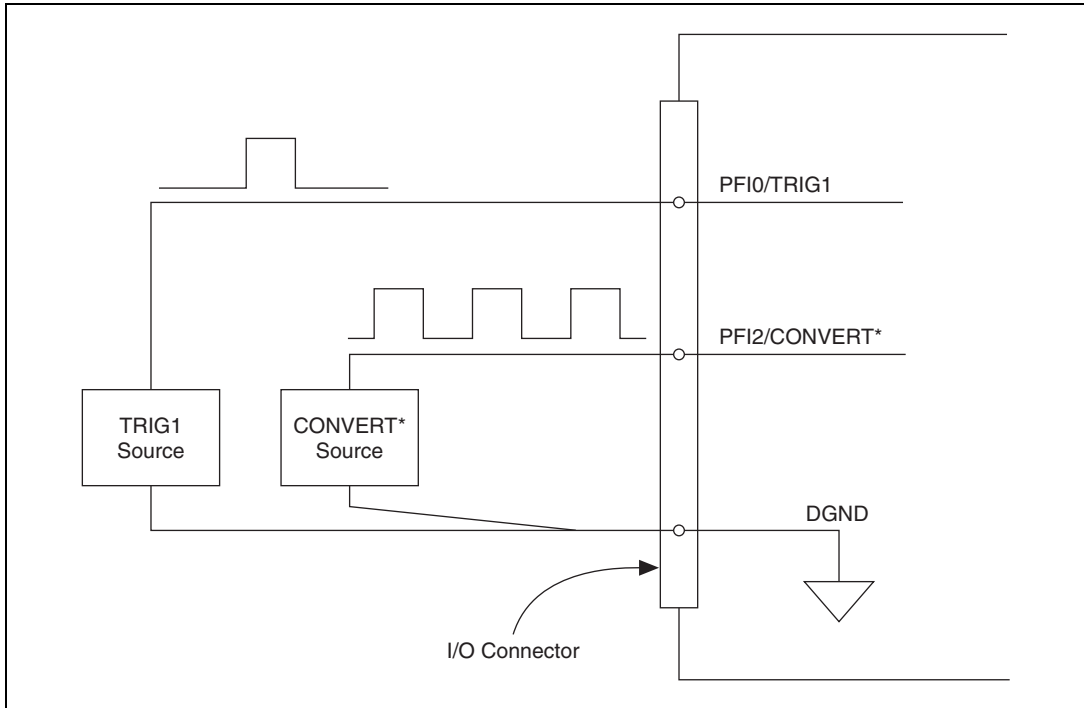

Figure 4-10. Timing I/O Connections

Programmable Function Input Connections

There are a total of 13 internal timing signals that you can externally control from the PFI pins. The source for each of these signals is software selectable from any PFI when you want external control. This flexible routing scheme reduces the need to change the physical wiring to the device I/O connector for applications requiring alternative wiring.

You can individually enable each PFI pin to output a specific internal timing signal. For example, if you need the CONVERT* signal as an output on the I/O connector, software can turn on the output driver for the PFI2/CONVERT* pin. Be careful not to drive a PFI signal externally when it is configured as an output.

As an input, each PFI pin can be individually configured for edge or level detection and for polarity selection. You can use the polarity selection for any of the 13 timing signals, but the edge or level detection depends upon the particular timing signal being controlled. The detection requirements for each timing signal are listed within the section that discusses that individual signal.

In edge-detection mode, the minimum pulse width required is 10 ns. This requirement applies for both rising-edge and falling-edge polarity settings. There is no maximum pulse-width in edge-detect mode.

In level-detection mode, there are no minimum or maximum pulse-width requirements imposed by the PFIs themselves, but there may be limits imposed by the particular timing signal being controlled. These requirements are listed later in this chapter.

DAQ Timing Connections

The DAQ timing signals are TRIG1, TRIG2, STARTSCAN, CONVERT*, AIGATE, SISOURCE, SCANCLK, and EXTSTROBE*.

Posttriggered data acquisition allows you to view only data that is acquired after a trigger event is received. A typical posttriggered DAQ sequence is shown in Figure 4-11.

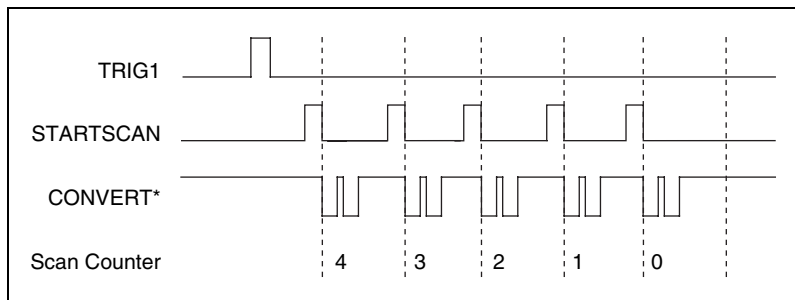

Figure 4-11. Typical Posttriggered Acquisition

Pretriggered data acquisition allows you to view data that is acquired before the trigger of interest in addition to data acquired after the trigger.

Figure 4-12 shows a typical pretriggered DAQ sequence. The description for each signal shown in these figures is included later in this chapter.

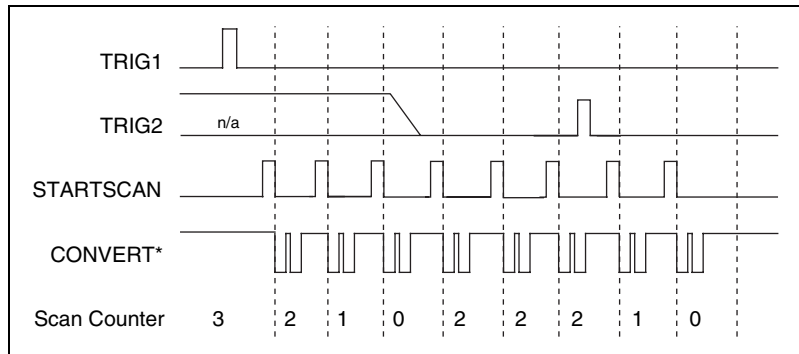

Figure 4-12. Typical Pretriggered Acquisition

TRIG1 Signal

Any PFI pin can externally input the TRIG1 signal, which is available as an output on the PFI0/TRIG1 pin. Refer to Figures 4-11 and 4-12 for the relationship of TRIG1 to the DAQ sequence.

Refer to Figures 4-11 and 4-12 for the relationship of TRIG1 to the DAQ sequence.

As an input, TRIG1 is configured in the edge-detection mode. You can select any PFI pin as the source for TRIG1 and configure the polarity selection for either rising or falling edge. The selected edge of TRIG1 starts the DAQ sequence for both posttriggered and pretriggered acquisitions.

As an output, TRIG1 reflects the action that initiates a DAQ sequence, even if the acquisition is being externally triggered by another PFI. The output is an active high pulse with a pulse width of 50 to 100 ns. This output is set to high-impedance at startup.

Figures 4-13 and 4-14 show the input and output timing requirements for TRIG1.

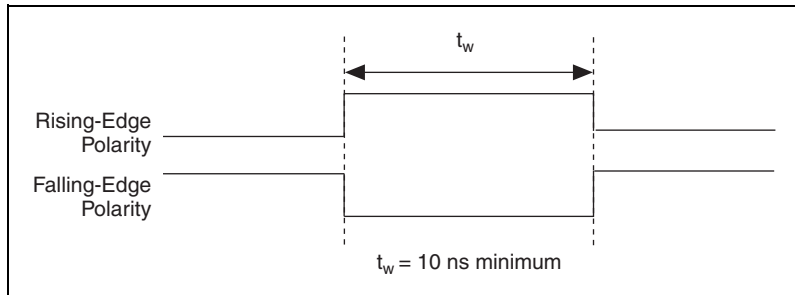

Figure 4-13. TRIG1 Input Signal Timing

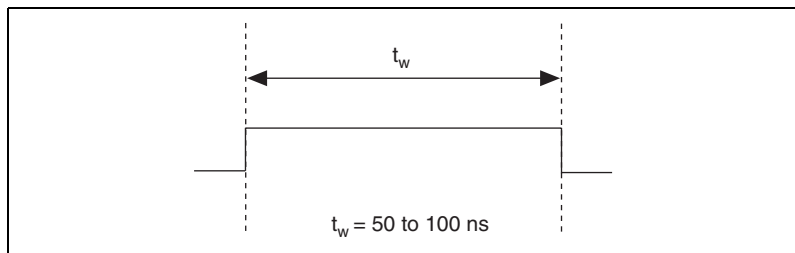

Figure 4-14. TRIG1 Output Signal Timing

The device also uses TRIG1 to initiate pretriggered DAQ operations. In most pretriggered applications, TRIG1 is generated by a software trigger. Refer to the TRIG2 signal description for a complete description of the use of TRIG1 and TRIG2 in a pretriggered DAQ operation.

TRIG2 Signal

Any PFI pin can externally input the TRIG2 signal, which is available as an output on the PFI1/TRIG2 pin. Refer to Figure 4-12 for the relationship of TRIG2 to the DAQ sequence.

As an input, TRIG2 is configured in the edge-detection mode. You can select any PFI pin as the source for TRIG2 and configure the polarity selection for either rising or falling edge. The selected edge of TRIG2 initiates the posttriggered phase of a pretriggered acquisition sequence. In pretriggered mode, the TRIG1 signal initiates the data acquisition. The scan counter indicates the minimum number of scans before TRIG2 can be recognized. After the scan counter decrements to zero, it is loaded with the number of posttrigger scans to acquire while the acquisition continues. The

device ignores TRIG2 if it is asserted prior to the scan counter decrementing to zero. After the selected edge of TRIG2 is received, the device acquires a fixed number of scans and the acquisition stops. This mode acquires data both before and after receiving TRIG2.

As an output, TRIG2 reflects the posttrigger in a pretriggered acquisition sequence, even if the acquisition is being externally triggered by another PFI. TRIG2 is not used in posttriggered data acquisition. The output is an active high pulse with a pulse width of 50 to 100 ns. This output is set to high-impedance at startup.

Figures 4-15 and 4-16 show the input and output timing requirements for TRIG2.

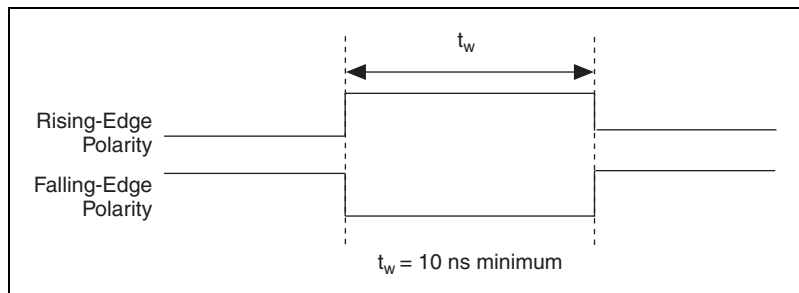

Figure 4-15. TRIG2 Input Signal Timing

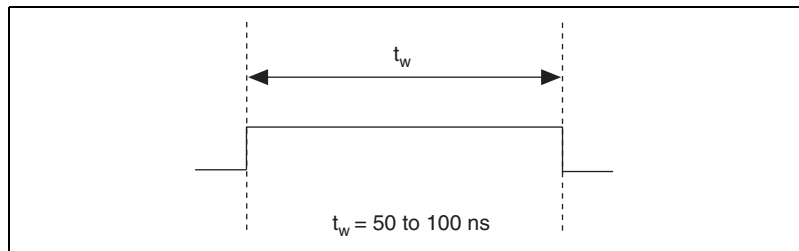

Figure 4-16. TRIG2 Output Signal Timing

STARTSCAN Signal

Any PFI pin can receive as an input the STARTSCAN signal, which is available as an output on the PFI7/STARTSCAN pin. Refer to Figures 4-11 and 4-12 for the relationship of STARTSCAN to the DAQ sequence.

As an input, STARTSCAN is configured in the edge-detection mode. You can select any PFI pin as the source for STARTSCAN and configure the polarity selection for either rising or falling edge. The selected edge of STARTSCAN initiates a scan. The sample interval counter starts if you select internally triggered CONVERT*.

As an output, STARTSCAN reflects the actual start pulse that initiates a scan, even if the starts are being externally triggered by another PFI. You have two output options. The first is an active high pulse with a pulse width of 50 to 100 ns, which indicates the start of the scan. The second action is an active high pulse that terminates at the start of the last conversion in the scan, which indicates a scan in progress. STARTSCAN is deasserted t_{off} after the last conversion in the scan is initiated. This output is set to high-impedance at startup.

Figures 4-17 and 4-18 show the input and output timing requirements for STARTSCAN.

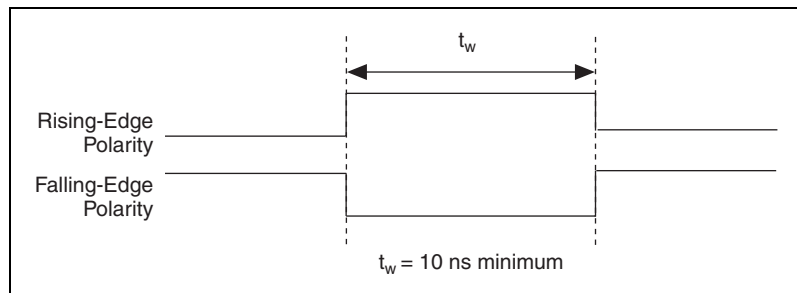

Figure 4-17. STARTSCAN Input Signal Timing

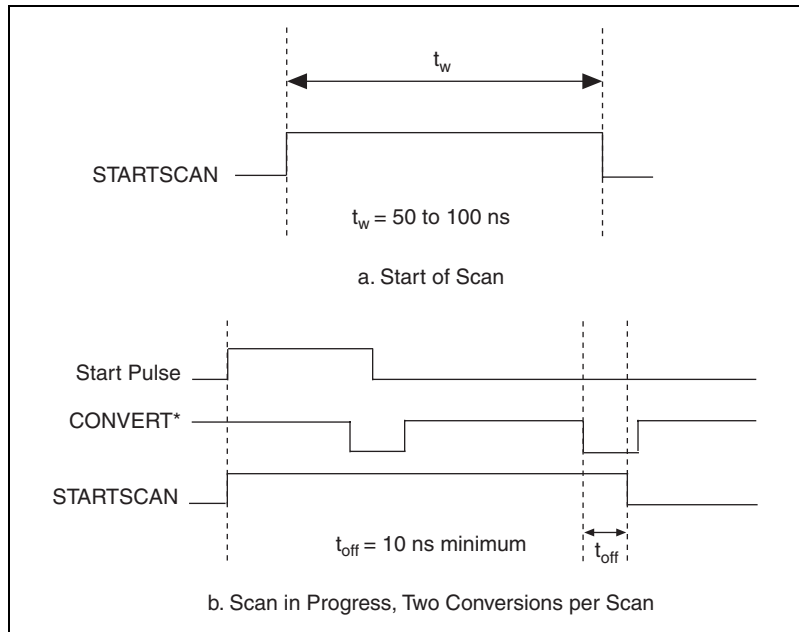

Figure 4-18. STARTSCAN Output Signal Timing

CONVERT* pulses are masked off until the device generates STARTSCAN. If you use internally generated conversions, the first CONVERT* appears when the onboard sample interval counter reaches zero. If you select an external CONVERT*, the first external pulse after STARTSCAN generates a conversion. The STARTSCAN pulses should be separated by at least one scan period.

A counter on the NI 6034E/6035E/6036E internally generates STARTSCAN unless you select an external source. The TRIG1 signal starts this counter, and software or the sample counter stops STARTSCAN.

Scans generated by either an internal or external STARTSCAN signal are inhibited unless they occur within a DAQ sequence. Scans occurring within a DAQ sequence may be gated by either the hardware (AIGATE) signal or software command register gate.

CONVERT* Signal

Any PFI pin can externally input the CONVERT* signal, which is available as an output on the PFI2/CONVERT* pin. Refer to Figures 4-11 and 4-12 for the relationship of CONVERT* to the DAQ sequence.

As an input, CONVERT* is configured in the edge-detection mode. You can select any PFI pin as the source for CONVERT* and configure the polarity selection for either rising or falling edge. The selected edge of CONVERT* initiates an A/D conversion.

The ADC switches to hold mode within 60 ns of the selected edge. This hold-mode delay time is a function of temperature and does not vary from one conversion to the next. CONVERT* pulses should be separated by at least 5 μ s (200 kHz sample rate).

As an output, CONVERT* reflects the actual convert pulse that is connected to the ADC, even if the conversions are being externally generated by another PFI. The output is an active low pulse with a pulse width of 50 to 150 ns. This output is set to high-impedance at startup.

Figures 4-19 and 4-20 show the input and output timing requirements for CONVERT*.

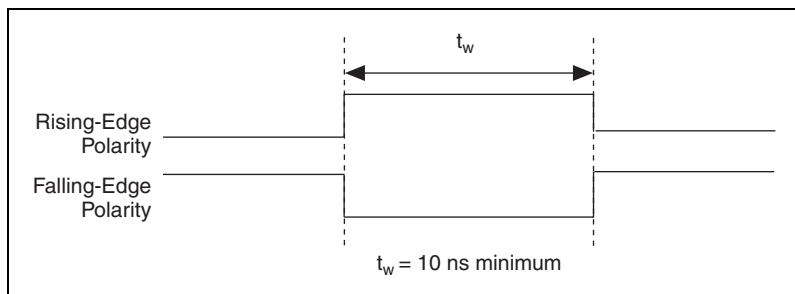

Figure 4-19. CONVERT* Input Signal Timing

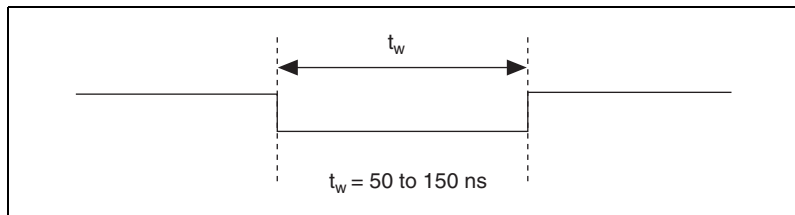

Figure 4-20. CONVERT* Output Signal Timing

The sample interval counter on the NI 6034E/6035E/6036E normally generates the CONVERT* signal unless you select some external source. The counter is started by STARTSCAN and continues to count down and reload itself until the scan is finished. It then reloads itself in preparation for the next STARTSCAN pulse.

A/D conversions generated by either an internal or external CONVERT* signal are inhibited unless they occur within a DAQ sequence. Scans occurring within a DAQ sequence may be gated by either the hardware (AIGATE) signal or software command register gate.

AIGATE Signal

Any PFI pin can externally input the AIGATE signal, which is not available as an output on the I/O connector. AIGATE can mask off scans in a DAQ sequence. You can configure the PFI pin you select as the source for the AIGATE signal in either the level-detection or edge-detection mode. You can configure the polarity selection for the PFI pin for either active high or active low.

In the level-detection mode, if AIGATE is active, the STARTSCAN signal is masked off and no scans can occur. In the edge-detection mode, the first active edge disables STARTSCAN, and the second active edge enables STARTSCAN.

The AIGATE signal can neither stop a scan in progress nor continue a previously gated-off scan; in other words, once a scan has started, AIGATE does not gate off conversions until the beginning of the next scan. Conversely, if conversions are being gated off, AIGATE does not gate them back on until the beginning of the next scan.

SISOURCE Signal

Any PFI pin can externally input the SISOURCE signal, which is not available as an output on the I/O connector. The onboard scan interval counter uses the SISOURCE signal as a clock to time the generation of the STARTSCAN signal. You must configure the PFI pin you select as the source for SISOURCE in the level-detection mode. You can configure the polarity selection for the PFI pin for either active high or active low.

The maximum allowed frequency is 20 MHz, with a minimum pulse width of 23 ns high or low. There is no minimum frequency.

Either the 20 MHz or 100 kHz internal timebase generates SISOURCE unless you select some external source. Figure 4-21 shows the timing requirements for SISOURCE.

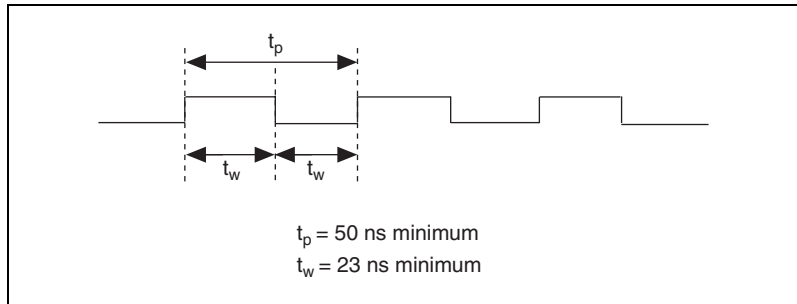

Figure 4-21. SISOURCE Signal Timing

SCANCLK Signal

SCANCLK is an output-only signal that generates a pulse with the leading edge occurring approximately 50 to 100 ns after an A/D conversion begins. The polarity of this output is software-selectable but is typically configured so that a low-to-high leading edge can clock external analog input multiplexers indicating when the input signal has been sampled and can be removed. This signal has a 400 to 500 ns pulse width and is software enabled.



Note When using NI-DAQ, SCANCLK polarity is low-to-high and cannot be changed programmatically.

Figure 4-22 shows the timing for SCANCLK.

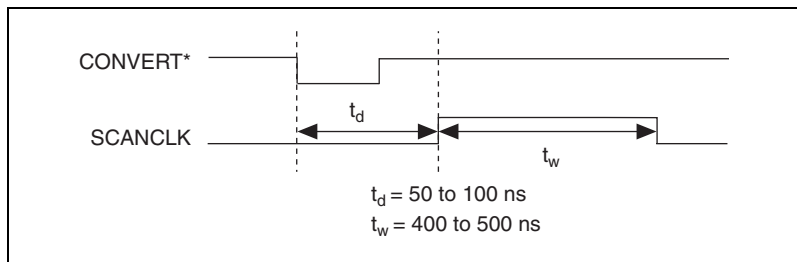

Figure 4-22. SCANCLK Signal Timing

EXTSTROBE* Signal

EXTSTROBE* is an output-only signal that generates either a single pulse or a sequence of eight pulses in the hardware-strobe mode. An external device can use this signal to latch signals or to trigger events. In the single-pulse mode, software controls the level of EXTSTROBE*. A 10 μs and a 1.2 μs clock are available for generating a pulse sequence in the hardware-strobe mode.



Note EXTSTROBE* cannot be enabled through NI-DAQ.

Figure 4-23 shows the timing for the hardware-strobe mode EXTSTROBE* signal.

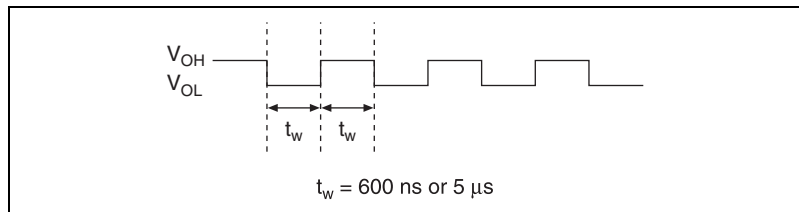

Figure 4-23. EXTSTROBE* Signal Timing

Waveform Generation Timing Connections

The analog group defined for the NI 6034E/6035E/6036E is controlled by WFTRIG, UPDATE*, and UISOURCE.

WFTRIG Signal

Any PFI pin can externally input the WFTRIG signal, which is available as an output on the PFI6/WFTRIG pin.

As an input, WFTRIG is configured in the edge-detection mode. You can select any PFI pin as the source for WFTRIG and configure the polarity selection for either rising or falling edge. The selected edge of WFTRIG starts the waveform generation for the DACs. The update interval (UI) counter is started if you select the internally generated UPDATE* signal.

As an output, WFTRIG reflects the trigger that initiates waveform generation, even if the waveform generation is being externally triggered by another PFI. The output is an active high pulse with a pulse width of 50 to 100 ns. This output is set to high-impedance at startup.

Figures 4-24 and 4-25 show the input and output timing requirements for WFTRIG.

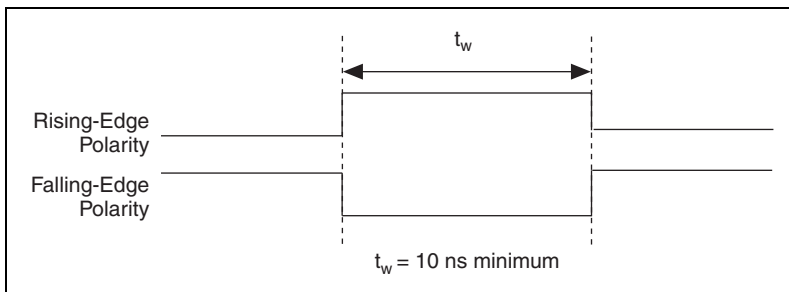

Figure 4-24. WFTRIG Input Signal Timing

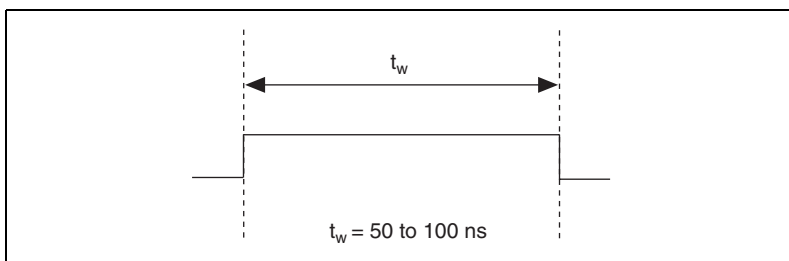

Figure 4-25. WFTRIG Output Signal Timing

UPDATE* Signal

Any PFI pin can externally input the UPDATE* signal, which is available as an output on the PFI5/UPDATE* pin.

As an input, UPDATE* is configured in the edge-detection mode. You can select any PFI pin as the source for UPDATE* and configure the polarity selection for either rising or falling edge. The selected edge of UPDATE* updates the outputs of the DACs. In order to use UPDATE*, you must set the DACs to posted-update mode.

As an output, UPDATE* reflects the actual update pulse that is connected to the DACs, even if the updates are being externally generated by another PFI. The output is an active low pulse with a pulse width of 300 to 350 ns. This output is set to high-impedance at startup.

Figures 4-26 and 4-27 show the input and output timing requirements for UPDATE*.

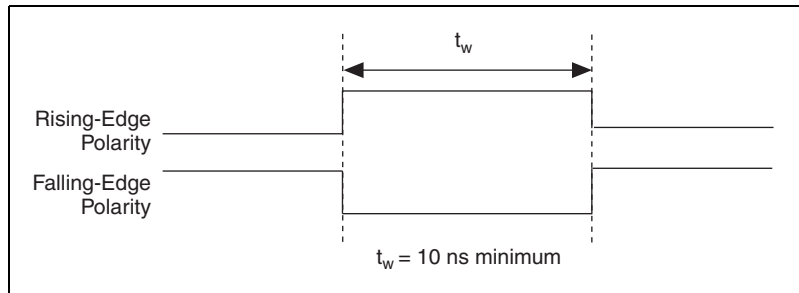

Figure 4-26. UPDATE* Input Signal Timing

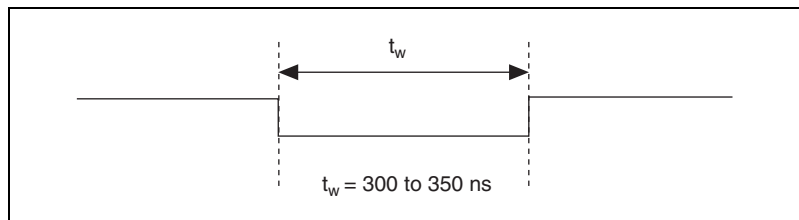

Figure 4-27. UPDATE* Output Signal Timing

The DACs are updated within 100 ns of the leading edge. Separate the UPDATE* pulses with enough time that new data can be written to the DAC latches.

The device UI counter normally generates UPDATE* unless you select some external source. The UI counter is started by the WFTRIG signal and can be stopped by software or the internal Buffer Counter. D/A conversions generated by either an internal or external UPDATE* signal do not occur when gated by the software command register gate.

UISOURCE Signal

Any PFI pin can externally input the UISOURCE signal, which is not available as an output on the I/O connector. The UI counter uses UISOURCE as a clock to time the generation of the UPDATE* signal. You must configure the PFI pin you select as the source for UISOURCE in the level-detection mode. You can configure the polarity selection for the PFI pin for either active high or active low. Figure 4-28 shows the timing requirements for UISOURCE.

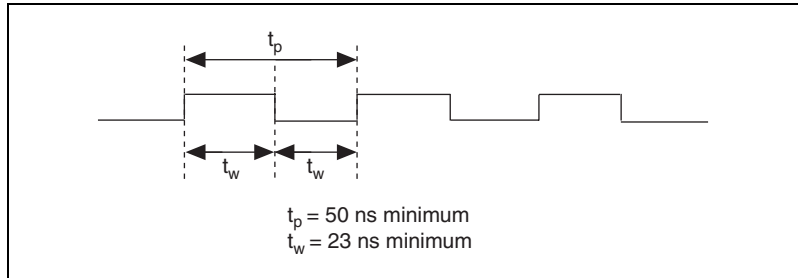

Figure 4-28. UISOURCE Signal Timing

The maximum allowed frequency is 20 MHz, with a minimum pulse width of 23 ns high or low. There is no minimum frequency.

Either the 20 MHz or 100 kHz internal timebase normally generates UISOURCE unless you select some external source.

General-Purpose Timing Signal Connections

The general-purpose timing signals are GPCTR0_SOURCE, GPCTR0_GATE, GPCTR0_OUT, GPCTR0_UP_DOWN, GPCTR1_SOURCE, GPCTR1_GATE, GPCTR1_OUT, GPCTR1_UP_DOWN, and FREQ_OUT.

GPCTR0_SOURCE Signal

Any PFI pin can externally input the GPCTR0_SOURCE signal, which is available as an output on the PFI8/GPCTR0_SOURCE pin.

As an input, GPCTR0_SOURCE is configured in the edge-detection mode. You can select any PFI pin as the source for GPCTR0_SOURCE and configure the polarity selection for either rising or falling edge.

As an output, GPCTR0_SOURCE reflects the actual clock connected to general-purpose counter 0, even if another PFI is externally inputting the source clock. This output is set to high-impedance at startup.

Figure 4-29 shows the timing requirements for the GPCTRO_SOURCE signal.

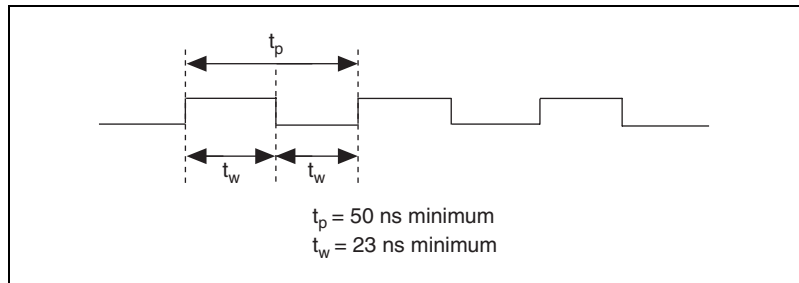

Figure 4-29. GPCTRO_SOURCE Signal Timing

The maximum allowed frequency is 20 MHz, with a minimum pulse width of 23 ns high or low. There is no minimum frequency.

The 20 MHz or 100 kHz timebase normally generates GPCTRO_SOURCE unless you select some external source.

GPCTRO_GATE Signal

Any PFI pin can externally input the GPCTRO_GATE signal, which is available as an output on the PFI9/GPCTRO_GATE pin.

As an input, GPCTRO_GATE is configured in the edge-detection mode. You can select any PFI pin as the source for GPCTRO_GATE and configure the polarity selection for either rising or falling edge. You can use the gate signal in a variety of different applications to perform actions such as starting and stopping the counter, generating interrupts, and saving the counter contents.

As an output, GPCTRO_GATE reflects the actual gate signal connected to general-purpose counter 0, even if the gate is being externally generated by another PFI. This output is set to high-impedance at startup.

Figure 4-30 shows the timing requirements for the GPCTRO_GATE signal.

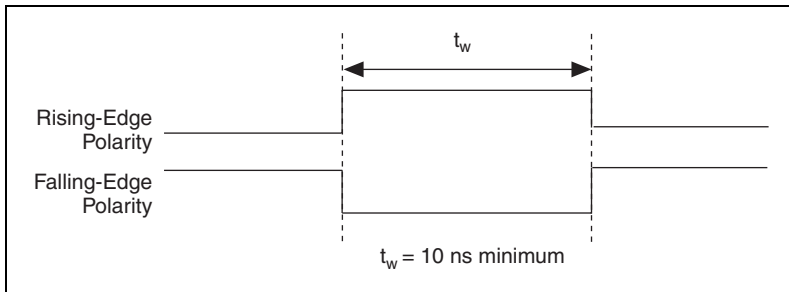

Figure 4-30. GPCTRO_GATE Signal Timing in Edge-Detection Mode

GPCTRO_OUT Signal

This signal is available only as an output on the GPCTRO_OUT pin. The GPCTRO_OUT signal reflects the terminal count (TC) of general-purpose counter 0. You have two software-selectable output options—pulse on TC and toggle output polarity on TC. The output polarity is software-selectable for both options. This output is set to high-impedance at startup.

Figure 4-31 shows the timing of GPCTRO_OUT.



Note When using external clocking mode with correlated DIO, this pin is used as an input for the external clock.

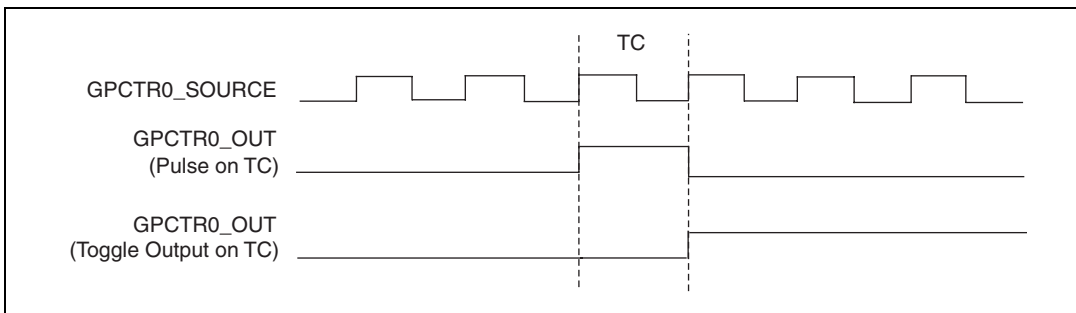

Figure 4-31. GPCTRO_OUT Signal Timing

GPCTRO_UP_DOWN Signal

This signal can be externally input on the DIO6 pin and is not available as an output on the I/O connector. The general-purpose counter 0 counts down when this pin is at a logic low and count up when it is at a logic high. You

can disable this input so that software can control the up-down functionality and leave the DIO6 pin free for general use.

GPCTR1_SOURCE Signal

Any PFI pin can externally input the GPCTR1_SOURCE signal, which is available as an output on the PFI3/GPCTR1_SOURCE pin.

As an input, GPCTR1_SOURCE is configured in the edge-detection mode. You can select any PFI pin as the source for GPCTR1_SOURCE and configure the polarity selection for either rising or falling edge.

As an output, GPCTR1_SOURCE monitors the actual clock connected to general-purpose counter 1, even if the source clock is being externally generated by another PFI. This output is set to high-impedance at startup.

Figure 4-32 shows the timing requirements for GPCTR1_SOURCE.

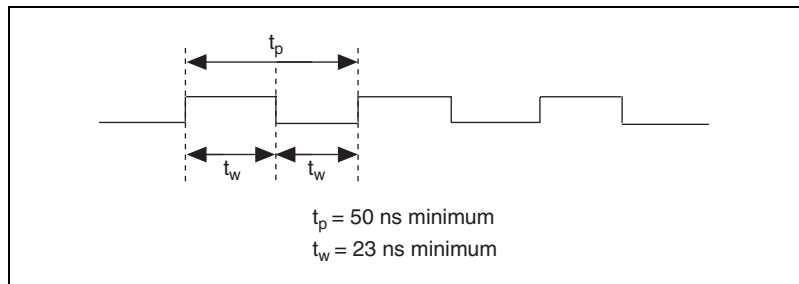

Figure 4-32. GPCTR1_SOURCE Signal Timing

The maximum allowed frequency is 20 MHz, with a minimum pulse width of 23 ns high or low. There is no minimum frequency limitation.

The 20 MHz or 100 kHz timebase normally generates the GPCTR1_SOURCE unless you select some external source.

GPCTR1_GATE Signal

Any PFI pin can externally input the GPCTR1_GATE signal, which is available as an output on the PFI4/GPCTR1_GATE pin.

As an input, GPCTR1_GATE is configured in edge-detection mode. You can select any PFI pin as the source for GPCTR1_GATE and configure the polarity selection for either rising or falling edge. You can use the gate signal in a variety of different applications to perform such actions as

starting and stopping the counter, generating interrupts, and saving the counter contents.

As an output, GPCTR1_GATE monitors the actual gate signal connected to general-purpose counter 1, even if the gate is being externally generated by another PFI. This output is set to high-impedance at startup.

Figure 4-33 shows the timing requirements for GPCTR1_GATE.

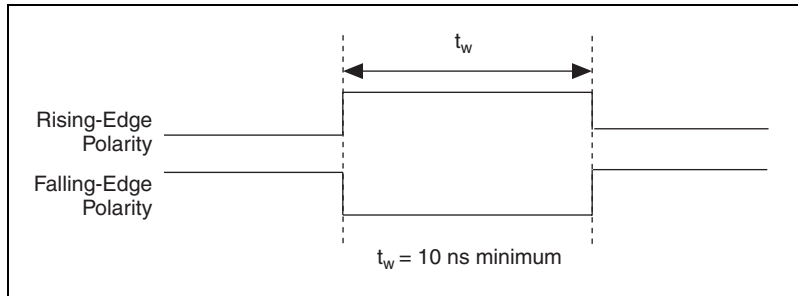

Figure 4-33. GPCTR1_GATE Signal Timing in Edge-Detection Mode

GPCTR1_OUT Signal

This signal is available only as an output on the GPCTR1_OUT pin. The GPCTR1_OUT signal monitors the TC device general-purpose counter 1. You have two software-selectable output options—pulse on TC and toggle output polarity on TC. The output polarity is software-selectable for both options. This output is set to high-impedance at startup.

Figure 4-34 shows the timing requirements for GPCTR1_OUT.

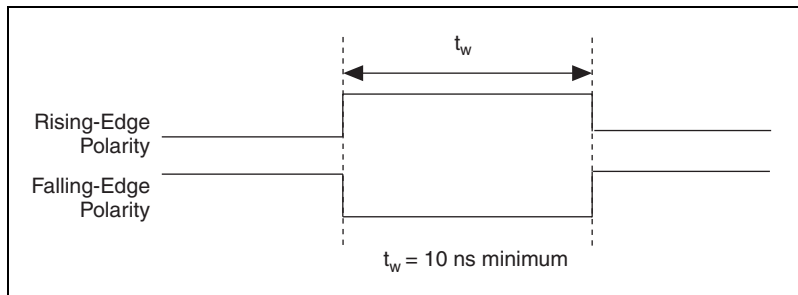

Figure 4-34. GPCTR1_OUT Signal Timing

GPCTR1_UP_DOWN Signal

This signal can be externally input on the DIO7 pin and is not available as an output on the I/O connector. General-purpose counter 1 counts down when this pin is at a logic low and counts up at a logic high. This input can be disabled so that software can control the up-down functionality and leave the DIO7 pin free for general use.

Figure 4-35 shows the timing requirements for the GATE and SOURCE input signals and the timing specifications for the OUT output signals of the NI 6034E/6035E/6036E.

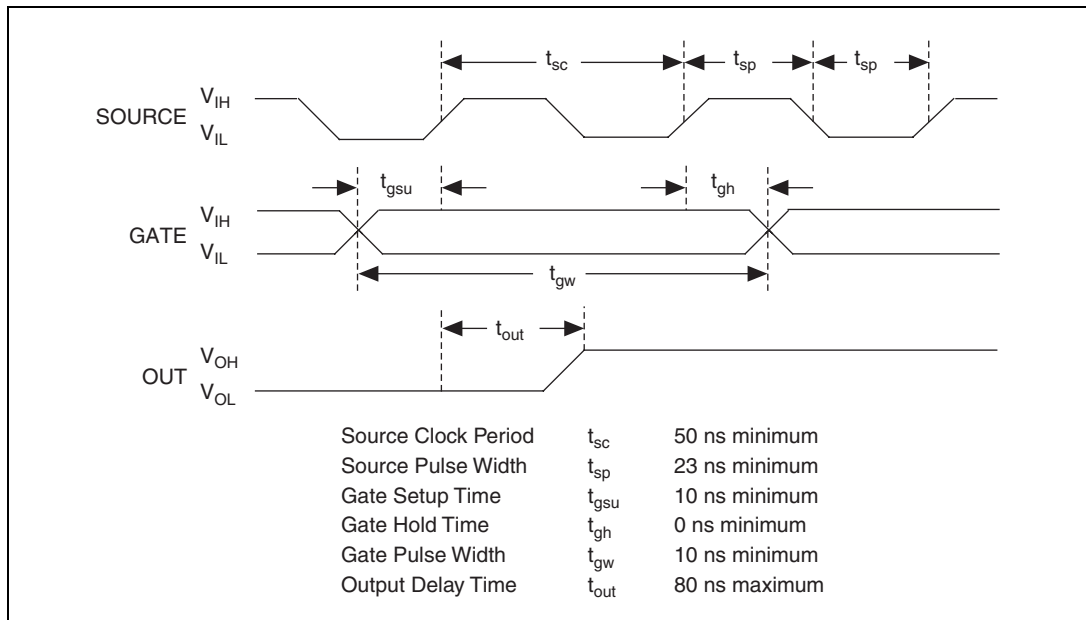

Figure 4-35. GPCTR Timing Summary

The GATE and OUT signal transitions shown in Figure 4-35 are referenced to the rising edge of the SOURCE signal. The assumption for this timing diagram is that the counters are programmed to count rising edges. The same timing diagram, but with the source signal inverted and referenced to the falling edge of the source signal, would apply when the counter is programmed to count falling edges.

The GATE input timing parameters are referenced to the signal at the SOURCE input or to one of the internally generated signals on the NI 6034E/6035E/6036E. Figure 4-35 shows the GATE signal referenced to the rising edge of a source signal. The gate must be valid (either high or

low) for at least 10 ns before the rising or falling edge of a source signal for the gate to take effect at that source edge, as shown by t_{gsu} and t_{gh} in Figure 4-35. The gate signal is not required to be held after the active edge of the source signal.

If you use an internal timebase clock, the gate signal cannot be synchronized with the clock. In this case, gates applied close to a source edge take effect either on that source edge or on the next one. This arrangement results in an uncertainty of one source clock period with respect to unsynchronized gating sources.

The OUT output timing parameters are referenced to the signal at the SOURCE input or to one of the internally generated clock signals on the NI 6034E/6035E/6036E. Figure 4-35 shows the OUT signal referenced to the rising edge of a source signal. Any OUT signal state changes occur within 80 ns after the rising or falling edge of the source signal.

FREQ_OUT Signal

This signal is available only as an output on the FREQ_OUT pin. The device frequency generator outputs the FREQ_OUT pin. The frequency generator is a 4-bit counter that can divide its input clock by the numbers 1 through 16. The input clock of the frequency generator is software selectable from the internal 10 MHz and 100 kHz timebases. The output polarity is software selectable. This output is set to high-impedance at startup.

Field Wiring Considerations

Environmental noise can seriously affect the accuracy of measurements made with the device if you do not take proper care when running signal wires between signal sources and the device. The following recommendations apply mainly to analog input signal routing to the device, although they also apply to signal routing in general.

Minimize noise pickup and maximize measurement accuracy by taking the following precautions:

- Use differential analog input connections to reject common-mode noise.
- Use individually shielded, twisted-pair wires to connect analog input signals to the device. With this type of wire, the signals attached to the CH+ and CH- inputs are twisted together and then covered with a shield. You then connect this shield only at one point to the signal

source ground. This kind of connection is required for signals traveling through areas with large magnetic fields or high electromagnetic interference.

- Route signals to the device carefully. Keep cabling away from noise sources. The most common noise source in a computer-based DAQ system is the video monitor. Separate the monitor from the analog signals as far as possible.

The following recommendations apply for all signal connections to the NI 6034E/6035E/6036E:

- Separate device signal lines from high-current or high-voltage lines. These lines can induce currents in or voltages on the device signal lines if they run in parallel paths at a close distance. To reduce the magnetic coupling between lines, separate them by a reasonable distance if they run in parallel or run the lines at right angles to each other.
- Do not run signal lines through conduits that also contain power lines.
- Protect signal lines from magnetic fields caused by electric motors, welding equipment, breakers, or transformers by running them through special metal conduits.

For more information, refer to the NI Developer Zone tutorial, *Field Wiring and Noise Consideration for Analog Signals*, available at ni.com/zone.

Calibration

This chapter discusses the calibration procedures for the NI 6034E/6035E/6036E. NI-DAQ includes calibration functions for performing all the steps in the calibration process.

Calibration refers to the process of minimizing measurement and output voltage errors by making small circuit adjustments. On the NI 6034E/6035E/6036E, these adjustments take the form of writing values to onboard calibration DACs (CalDACs).

Some form of device calibration is required for most applications. If you do not calibrate your device, your signals and measurements could have very large offset, gain, and linearity errors.

Three levels of calibration are available to you and described in this chapter. The first level is the fastest, easiest, and least accurate, whereas the last level is the slowest, most difficult, and most accurate.

Loading Calibration Constants

The NI 6034E/6035E/6036E is factory calibrated before shipment at approximately 25 °C to the levels indicated in Appendix A, *Specifications*. The associated calibration constants—the values that were written to the CalDACs to achieve calibration in the factory—are stored in the onboard nonvolatile memory (EEPROM). Because the CalDACs have no memory capability, they do not retain calibration information when the device is unpowered. Loading calibration constants refers to the process of loading the CalDACs with the values stored in the EEPROM. NI-DAQ determines when loading calibration constants is necessary and does it automatically. If you are not using NI-DAQ, you must load these values.

In the EEPROM, there is a user-modifiable calibration area in addition to the permanent factory calibration area. The user-modifiable calibration area allows you to load the CalDACs with values either from the original factory calibration or from a calibration that you subsequently performed.

This method of calibration is not very accurate because it does not take into account the fact that the device measurement and output voltage errors can vary with time and temperature. You should self-calibrate when the device is installed in the environment in which it is used.

Self-Calibration

The NI 6034E/6035E/6036E can measure and correct for almost all of its calibration-related errors without any external signal connections. NI software provides a self-calibration method. This self-calibration process, which generally takes less than two minutes, is the preferred method of assuring accuracy in your application. Initiate self-calibration to minimize the effects of any offset and gain drifts, particularly those due to warming.

Immediately after self-calibration, the only significant residual calibration error could be gain error due to time or temperature drift of the onboard voltage reference. This error is addressed by external calibration, which is discussed in the *External Calibration* section. If you are interested primarily in relative measurements, you can ignore a small amount of gain error, and self-calibration should be sufficient.

External Calibration

The NI 6034E/6035E/6036E has an onboard calibration reference to ensure the accuracy of self-calibration. Its specifications are listed in Appendix A, *Specifications*. The reference voltage is measured at the factory and stored in the EEPROM for subsequent self-calibrations. This voltage is stable enough for most applications, but if you are using your device at an extreme temperature or if the onboard reference has not been measured for a year or more, you may wish to externally calibrate your device.

An external calibration refers to calibrating your device with a known external reference rather than relying on the onboard reference. Redetermining the value of the onboard reference is part of this process, and you can save the results in the EEPROM, so you should not have to perform an external calibration often. You can externally calibrate your device by calling the NI-DAQ calibration function.

To externally calibrate your device, be sure to use a very accurate external reference. The reference should be several times more accurate than the device itself.

Other Considerations

The CalDACs adjust the gain error of each AO channel by adjusting the value of the reference voltage supplied to that channel. This calibration mechanism is designed to work only with the internal 10 V reference. Therefore, in general, it is not possible to calibrate the AO gain error when using an external reference. In this case, it is advisable to account for the nominal gain error of the AO channel either in software or with external hardware. Refer to Appendix A, *Specifications*, for analog output gain error information.

For a detailed calibration procedure for the NI 6034E/6035E/6036E, refer to the *E Series Calibration Procedure* by clicking **Manual Calibration Procedures** at ni.com/calibration.

Specifications

This appendix lists the specifications of the NI 6034E/6035E/6036E. These specifications are typical at 25 °C unless otherwise noted. The first section provides the specifications for the PCI-bus devices (NI PCI-6034E/6035E/6036E) and the second section provides the specifications for the PCMCIA devices (DAQCard-6036E).

PCI Bus

Analog Input

Input Characteristics

- Number of channels 16 single-ended or 8 differential (software-selectable per channel)
- Type of ADC..... Successive approximation
- Resolution 16 bits, 1 in 65,536
- Sampling rate 200 kS/s guaranteed
- Input signal ranges Bipolar only

Device Gain (Software-Selectable)	Range
0.5	±10 V
1	±5 V
10	±500 mV
100	±50 mV

- Input coupling DC
- Max working voltage (signal + common mode) Each input should remain within ±11 V of ground

Overvoltage protection

Signal	Powered On (V)	Powered Off (V)
ACH<0..15>, AISENSE	±25	±15

FIFO buffer size.....512 samples

Data transfersDMA, interrupts, programmed I/O

DMA modesScatter-gather (Single transfer, demand transfer)

Configuration memory size512 words

Accuracy Information

Nominal Range at Full Scale (V)	Absolute Accuracy						Relative Accuracy		
	% of Reading		Offset (µV)	Noise + Quantization (µV)		Temp Drift (%/°C)	Absolute Accuracy at Full Scale (mV)	Resolution (µV)	
	24 Hours	1 Year		Single Pt.	Averaged			Single Point	Averaged
±10	0.0546	0.0588	±1601	±933	±82.4	0.0010	7.56	1,085	108.5
±5	0.0146	0.0188	±811	±467	±41.2	0.0005	1.79	542	52.24
±0.5	0.0546	0.0588	±100	±56.2	±5.04	0.0010	0.399	66.3	6.630
±0.05	0.0546	0.0588	±28.9	±28.2	±2.75	0.0010	0.0611	36.2	3.616

Note: Accuracies are valid for measurements following an internal E Series calibration. Averaged numbers assume dithering and averaging of 100 single-channel readings. Measurement accuracies are listed for operational temperatures within ± 1 °C of internal calibration temperature and ±10 °C of external or factory calibration temperature. The Absolute Accuracy at Full Scale calculations use the maximum range input voltage (for example, 10 V on the ±10 V range) at one-year accuracy, assuming averaging.

Transfer Characteristics

Relative accuracy.....±1.5 LSB typ, ±3.0 LSB max

DNL±0.5 LSB typ, ±1.0 LSB max

No missing codes.....16 bits, guaranteed

Offset error

Pregain error after calibration.....±1.0 µV max

Pregain error before calibration.....±28.8 mV max

Postgain error after calibration $\pm 157 \mu\text{V}$ max

Postgain error before calibration..... $\pm 40 \text{ mV}$ max

Gain error (relative to calibration reference)

After calibration (gain = 1) ± 74 ppm of reading max

Before calibration $\pm 18,900$ ppm of reading max

Gain \neq with gain error

adjusted to 0 at gain = 1 ± 200 ppm of reading max

Amplifier Characteristics

Input impedance

Normal powered on $100 \text{ G}\Omega$ in parallel with 100 pF

Powered off 820Ω

Overload 820Ω

Input bias current $\pm 200 \text{ pA}$

Input offset current $\pm 100 \text{ pA}$

CMRR (DC to 60 Hz)

Gain 0.5, 1.0 85 dB

Gain 10, 100 96 dB

Dynamic Characteristics

Bandwidth

Signal	Bandwidth
Small (-3 dB)	413 kHz
Large (1% THD)	490 kHz

Settling time for full-scale step

Gain 100 $\pm 4 \text{ LSB}$, $5 \mu\text{s}$ typ

Gain 0.5, 1, 10 $\pm 2 \text{ LSB}$, $5 \mu\text{s}$ max

System noise (LSB_{rms} , including quantization)

Gain	LSB_{rms}
0.5, 1.0	0.9
10	1.1
100	6.0

CrosstalkDC to 100 kHz

 Adjacent channels.....-75 dB

 Other channels ≤ -90 dB

Stability

Recommended warm-up time.....15 min

Offset temperature coefficient

 Pregain $\pm 20 \mu V/^{\circ}C$

 Postgain $\pm 175 \mu V/^{\circ}C$

Gain temperature coefficient ± 20 ppm/ $^{\circ}C$

Analog Output

- ◆ NI 6035E/6036E only

Output Characteristics

Number of channels.....2 voltage

Resolution

 NI 6035E12 bits, 1 in 4,096

 NI 6036E16 bits, 1 in 65,536

Max update rate

 DMA.....10 kHz, system dependent

 Interrupts.....1 kHz, system dependent

Type of DACDouble buffered, multiplying

FIFO buffer size.....None

Data transfers DMA, interrupts,
programmed I/O

DMA modes Scatter-gather
(Single transfer, demand transfer)

Accuracy Information

NI 6035E Accuracy Information

Nominal Range at Full Scale (V)	Absolute Accuracy					
	% of Reading			Offset (mV)	Temp Drift (%/°C)	Absolute Accuracy at Full Scale (mV)
	24 Hours	90 Days	1 Year			
±10	0.0177	0.0197	0.0219	± 5.933	0.0005	8.12

NI 6036E Accuracy Information

Nominal Range at Full Scale (V)	Absolute Accuracy					
	% of Reading			Offset (mV)	Temp Drift (%/°C)	Absolute Accuracy at Full Scale (mV)
	24 Hours	90 Days	1 Year			
±10	0.0089	0.0109	0.0131	±0.103	0.0005	2.41

Transfer Characteristics

Relative accuracy (INL) after calibration

NI 6035E..... ±0.3 LSB typ, ±0.5 LSB max
 NI 6036E..... ±2 LSB max

DNL after calibration

NI 6035E..... ±0.3 LSB typ, ±1.0 LSB max
 NI 6036E..... ±1 LSB max

Monotonicity

NI 6035E..... 12 bits, guaranteed after calibration
 NI 6036E..... 16 bits, guaranteed after calibration

Offset error

After calibration

NI 6035E±1.0 mV max

NI 6036E±305 µV max

Before calibration

NI 6035E±200 mV max

NI 6036E±44 mV max

Gain error (relative to internal reference)

After calibration

NI 6035E±100 ppm

NI 6036E±30.5 ppm

Before calibration

NI 6035E±0.75%

NI 6036E±0.50%

Voltage Output

Range±10 V

Output couplingDC

Output impedance0.1 Ω max

Current drive±5 mA max

ProtectionShort-circuit to ground

Power-on state (steady state)

NI 6035E±200 mV

NI 6036E±44 mV

Initial power-up glitch

Magnitude

NI 6035E±1.1 V

NI 6036E±2.2 V

Duration

NI 6035E2.0 ms

NI 6036E42 µs

Power reset glitch

Magnitude

NI 6035E..... ± 2.2 VNI 6036E..... ± 2.2 V

Duration

NI 6035E..... 4.2 μ sNI 6036E..... 42 μ s**Dynamic Characteristics**

Settling time for full-scale step

NI 6035E..... 10 μ s to ± 0.5 LSB accuracyNI 6036E..... 10 μ s to ± 4 LSB accuracy

Slew rate

NI 6035E..... 10 V/ μ sNI 6036E..... 15 V/ μ s

Noise

NI 6035E..... 200 μ V_{rms}, DC to 400 kHzNI 6036E..... 110 μ V_{rms}, DC to 400 kHz

Midscale transition glitch

Magnitude

NI 6035E..... ± 12 mVNI 6036E..... ± 10 mV

Duration

NI 6035E..... 2.0 μ sNI 6036E..... 1.0 μ s**Stability**

Offset temperature coefficient

NI 6035E..... ± 50 μ V/ $^{\circ}$ CNI 6036E..... ± 35 μ V/ $^{\circ}$ C

Gain temperature coefficient

NI 6035E..... ± 25 ppm/ $^{\circ}$ CNI 6036E..... ± 6.5 ppm/ $^{\circ}$ C

Digital I/O

Number of channels8 input/output

CompatibilityTTL/CMOS

DIO<0..7>

Digital logic levels

Level	Min	Max
Input low voltage	0 V	0.8 V
Input high voltage	2 V	5 V
Input low current ($V_{in} = 0$ V)	—	-320 μ A
Input high current ($V_{in} = 5$ V)	—	10 μ A
Output low voltage ($I_{OL} = 24$ mA)	—	0.4 V
Output high voltage ($I_{OH} = 13$ mA)	4.35 V	—

Power-on state.....Input (high-impedance),
50 k Ω pull up to +5 VDC

Data transfersProgrammed I/O

Transfer rate (1 word = 8 bits)50 kwords/s, typ

Constant sustainable rate1 to 10 kwords/s, typ

Timing I/O

Number of channels2 up/down counter/timers,
1 frequency scaler

Resolution

Counter/timers24 bits

Frequency scalers4 bits

CompatibilityTTL/CMOS

Base clocks available

Counter/timers20 MHz, 100 kHz

Frequency scalers10 MHz, 100 kHz

Base clock accuracy	$\pm 0.01\%$
Max source frequency	20 MHz
Min source pulse duration	10 ns in edge-detect mode
Min gate pulse duration	10 ns in edge-detect mode
Data transfers	DMA, interrupts, programmed I/O
DMA modes	Scatter-gather (Single transfer, demand transfer)

Triggers

Digital Trigger

Compatibility	TTL
Response	Rising or falling edge
Pulse width	10 ns min

RTSI

Trigger lines	7
---------------------	---

Calibration

Recommended warm-up time	15 min
Interval	1 year
External calibration reference	> 6 V and < 10 V
Onboard calibration reference	
Level	5.000 V (± 3.5 mV) (over full operating temperature, actual value stored in EEPROM)
Temperature coefficient	± 5 ppm/ $^{\circ}$ C max
Long-term stability	± 15 ppm/ $\sqrt{1,000}$ h

Power Requirement

+5 VDC ($\pm 5\%$)0.9 A



Note Excludes power consumed through V_{CC} available at the I/O connector.

Power available at I/O connector.....+4.65 to +5.25 VDC at 1 A

Physical

Dimensions
(not including connectors)17.5 by 10.6 cm (6.9 by 4.2 in.)

I/O connector68-pin male SCSI-II type

Maximum Working Voltage

Maximum working voltage refers to the signal voltage plus the common-mode voltage.

Channel-to-earth ± 11 V, Installation Category I

Channel-to-channel..... ± 11 V, Installation Category I

Environmental

Operating temperature0 to 55 °C

Storage temperature-20 to 70 °C

Humidity10 to 90% RH, non-condensing

Safety

The NI 6034E/6035E/6036E meets the requirements of the following standards for safety and electrical equipment for measurement, control, and laboratory use:

- EN 61010-1:1993/A2:1995, IEC 61010-1:1990/A2:1995
- UL 3111-1:1994
- CAN/CSA c22.2 no. 1010.1:1992/A2:1997

Electromagnetic Compatibility

CE, C-Tick, and FCC Part 15 (Class A) Compliant

Electrical emissions..... EN 55011 Class A at 10 m
FCC Part 15A above 1 GHz

Electrical immunity..... Evaluated to EN 61326:1997/
A1:1998, Table 1



Note For full EMC compliance, you must operate this device with shielded cabling. In addition, all covers and filler panels must be installed. Refer to the Declaration of Conformity (DoC) for this product for any additional regulatory compliance information. To obtain the DoC for this product, click **Declaration of Conformity** at ni.com/hardref.nsf/. This Web site lists the DoCs by product family. Select the appropriate product family, followed by your product, and a link to the DoC appears in Adobe Acrobat format. Click the Acrobat icon to download or read the DoC.

PCMCIA Bus

Analog Input

Input Characteristics

Number of channels 16 single-ended or 8 differential
(software-selectable per channel)

Type of ADC..... Successive approximation

Resolution 16 bits, 1 in 65,536

Sampling rate 200 kS/s guaranteed

Input signal ranges Bipolar only

Board Gain (Software-selectable)	Range
0.5	±10 V
1	±5 V
10	±500 mV
100	±50 mV

Input coupling.....DC

Max working voltage
 (signal + common mode).....Each input should remain
 within ± 11 V of ground

Overvoltage protection

Signal	Powered On	Powered Off
ACH<0..15>	± 25	± 15
AISENSE	± 25	± 15

FIFO buffer size.....1,024 S

Data transfersInterrupts, programmed I/O

Configuration memory size512 words

Accuracy Information

Nominal Range at Full Scale (V)	Absolute Accuracy						Relative Accuracy		
	% of Reading		Offset (μ V)	Noise + Quantization (μ V)		Temp Drift (%/°C)	Absolute Accuracy at Full Scale (\pm mV)	Resolution (μ V)	
	24 Hours	1 Year		Single Pt.	Averaged			Single Pt.	Averaged
± 10	0.0549	0.0591	2,602.05	1,500.21	137.329	0.0010	8.653	1,808.17	180.82
± 5	0.0149	0.0191	1,311.53	750.10	68.665	0.0005	2.337	904.08	90.408
± 0.5	0.0549	0.0591	150.053	84.319	7.782	0.0010	0.454	102.463	10.246
± 0.05	0.0549	0.0591	33.905	32.779	3.204	0.0010	0.067	42.191	4.219

Note: Accuracies are valid for measurements following an internal E Series calibration. Averaged numbers assume dithering and averaging of 100 single-channel readings. Measurement accuracies are listed for operational temperatures within ± 1 °C of internal calibration temperature and ± 10 °C of external or factory calibration temperature.

Transfer Characteristics

Relative accuracy..... ± 6 LSB max

DNL ± 4 LSB, -2 LSB max

No missing codes.....15 bits

Offset error

Pregain error after calibration 1 μ V max
 Pregain error before calibration 3.0 mV max
 Postgain error after calibration ± 0.20 mV max
 Postgain error before calibration..... ± 50.1 mV

Gain error (relative to calibration reference)

After calibration (gain = 1) 77 ppm
 Before calibration 19,800 ppm
 Gain $\neq 1$ with gain error
 adjusted to 0 at gain = 1 200 ppm

Amplifier Characteristics**Input impedance**

Normal powered on 100 $\text{G}\Omega$ in parallel with 100 pF
 Powered off 820 Ω min
 Overload 820 Ω min

Input bias current ± 800 pA

Input offset current ± 100 pA

CMRR (DC to 60 Hz)

Gain 0.5, 1.0 85 dB
 Gain 10, 100 96 dB

Dynamic Characteristics**Bandwidth**

Signal	Bandwidth
Small (-3 dB)	413 kHz
Large (1% THD)	490 kHz

Settling time for full-scale step

Gain 0.5, 10, 100 ± 4.5 LSB, 5 μ s typ
 Gain = 1 ± 2 LSB, 5 μ s max

System noise (LSB_{rms} , including quantization)

Gain	Noise
0.5 to 1	1.5
10	1.7
100	7.0

CrosstalkDC to 100 kHz

 Adjacent channels.....-75 dB

 Other channels ≤ -90 dB

Stability

Recommended warm-up time.....30 min

Offset temperature coefficient

 Pregain $\pm 20 \mu V/^{\circ}C$

 Postgain $\pm 175 \mu V/^{\circ}C$

Gain temperature coefficient ± 20 ppm/ $^{\circ}C$

Analog Output

Output Characteristics

Number of channels2 voltage

Resolution16 bits, 1 in 65,536

Max update rate

 Interrupts.....1 kHz, system dependent

Type of DACDouble buffered, multiplying

FIFO buffer size.....None

Data transfersInterrupts, programmed I/O

Accuracy Information

Nominal Range (V)		Absolute Accuracy					Absolute Accuracy at Full Scale (mV)
		% of Reading			Offset (mV)	Temp Drift (%/°C)	
Positive FS	Negative FS	24 Hours	90 Days	1 Year			
10	-10	0.0091	0.0111	0.0133	1.22	0.0005	2.547
Note: Temp Drift applies only if ambient is greater than ± 10 °C of previous external calibration.							

Transfer Characteristics

Relative accuracy (INL)

After calibration ± 2 LSB max

DNL

After calibration ± 1 LSB max

Monotonicity 16 bits, guaranteed

Offset error

After calibration ± 305 μ V max

Before calibration ± 60 mV max

Gain error (relative to internal reference)

After calibration ± 30.5 ppm max

Before calibration $\pm 0.5\%$ of output max

Voltage Output

Range ± 10 V

Output coupling DC

Output impedance 0.1Ω max

Current drive ± 5 mA max

Protection Short-circuit to ground

Power-on state (steady state) ± 60 mV

Initial power-up glitch
 Magnitude.....±1.6 V
 Duration.....545 ms

Power reset glitch
 Magnitude.....±1.6 V
 Duration.....545 ms

Dynamic Characteristics

Settling time for full-scale step.....5 μs to 4.5 LSB accuracy
 Slew rate5 V/μs
 Noise160 μV_{rms}, DC to 400 kHz

Stability

Offset temperature coefficient±150 μV/°C
 Gain temperature coefficient±8 ppm/°C

Digital I/O

Number of channels.....8 input/output
 CompatibilityTTL/CMOS

DIO<0..7>

Digital logic levels

Level	Min	Max
Input low voltage	0 V	0.8 V
Input high voltage	2 V	5 V
Input low current (V _{in} = 0 V)	—	–320 μA
Input high current (V _{in} = 5 V)	—	10 μA
Output low voltage (I _{OL} = 24 mA)	—	0.4 V
Output high voltage (I _{OH} = 13 mA)	4.35 V	—

Power-on state Input (High-Z),
50 k Ω pull up to +5 VDC

Data transfers Programmed I/O

Timing I/O

Number of channels 2 up/down counter/timers,
1 frequency scaler

Resolution

Counter/timers 24 bits

Frequency scalars 4 bits

Compatibility TTL/CMOS

Base clocks available

Counter/timers 20 MHz, 100 kHz

Frequency scalars 10 MHz, 100 kHz

Base clock accuracy $\pm 0.01\%$

Max source frequency 20 MHz

Min source pulse duration 10 ns in edge-detect mode

Min gate pulse duration 10 ns in edge-detect mode

Data transfers Interrupts, programmed I/O

Triggers

Digital Trigger

Compatibility TTL

Response Rising or falling edge

Pulse width 10 ns min

Calibration

Recommended warm-up time 30 min

Interval 1 year

External calibration reference.....> 6 and < 10 V

Onboard calibration reference

Level5.000 V (± 3.5 mV) (actual value stored in EEPROM)

Temperature coefficient..... ± 5 ppm/ $^{\circ}\text{C}$ max

Long-term stability ± 15 ppm/ $\sqrt{1,000}$ h

Power Requirement

+5 VDC ($\pm 5\%$)300 mA



Note Excludes power consumed through V_{CC} available at the I/O connector.

Power available at I/O connector.....+4.65 to +5.25 VDC at 0.75 A

Physical

PC card type.....Type II

I/O connector68-position VHDCI female connector

Maximum Working Voltage

Maximum working voltage refers to the signal voltage plus the common-mode voltage.

Channel-to-earth ± 11 V, Installation Category I

Channel-to-channel..... ± 11 V, Installation Category I

Environmental

Operating temperature0 to 40 $^{\circ}\text{C}$ with a maximum internal device temperature of 70 $^{\circ}\text{C}$ as measured by onboard temperature sensor.

Storage temperature-20 to 70 $^{\circ}\text{C}$

Relative humidity	10 to 95% non-condensing
Maximum altitude	2,000 meters
Pollution degree (indoor use only)	2

Safety

The NI 6034E/6035E/6036E meets the requirements of the following standards for safety and electrical equipment for measurement, control, and laboratory use:

- EN 61010-1:1993/A2:1995, IEC 61010-1:1990/A2:1995
- UL 3111-1:1994
- CAN/CSA c22.2 no. 1010.1:1992/A2:1997

Electromagnetic Compatibility

CE, C-Tick, and FCC Part 15 (Class A) Compliant

Electrical emissions.....	EN 55011 Class A at 10 m FCC Part 15A above 1 GHz
---------------------------	--

Electrical immunity	Evaluated to EN 61326:1997/ A1:1998, Table 1
---------------------------	---



Note For full EMC compliance, you must operate this device with shielded cabling. In addition, all covers and filler panels must be installed. Refer to the Declaration of Conformity (DoC) for this product for any additional regulatory compliance information. To obtain the DoC for this product, click **Declaration of Conformity** at ni.com/hardref.nsf/. This Web site lists the DoCs by product family. Select the appropriate product family, followed by your product, and a link to the DoC appears in Adobe Acrobat format. Click the Acrobat icon to download or read the DoC.

Custom Cabling and Optional Connectors

This appendix describes the various cabling and connector options for the NI 6034E/6035E/6036E.

Custom Cabling

NI offers cables and accessories for you to prototype your application or to use if you frequently change device interconnections.

If you want to develop your own cable, however, adhere to the following guidelines for best results:

- For analog input signals, use shielded twisted-pair wires for each analog input pair for differential inputs. Tie the shield for each signal pair to the ground reference at the source.
- Route the analog lines separately from the digital lines.
- When using a cable shield, use separate shields for the analog and digital halves of the cable. Failure to do so results in noise coupling into the analog signals from transient digital signals.

Mating connectors and a backshell kit for making custom 68-pin cables are available from NI.

The parts in the following list are recommended for connectors that mate to the I/O connector on the NI 6034E/6035E/6036E.

- ◆ PCI-6034E/6035E/6036E
 - Honda 68-position, solder cup, female connector
 - Honda backshell
- ◆ DAQCard-6036E
 - Honda 68-Position, VHDCI

Optional Connectors

The following table shows the optional connector and cable assembly combinations you can use for each device.

Device	Connector	Cable Assembly
NI 6034E, NI 6035E, and NI 6036E	68-Pin E Series	SH6868, R6868
	50-Pin E Series	SH6850, R6850
DAQCard-6036E	68-Pin E Series	SHC68-68-EP, RC68-68
	50-Pin E Series	68M-50F adapter plus SHC68-68-EP or RC68-68 cable

Figure B-1 shows the pin assignments for the 68-pin E Series connector. This connector is available when you use the SH6868 or R6868 cable assemblies.

ACH8	34	68	ACH0
ACH1	33	67	AIGND
AIGND	32	66	ACH9
ACH10	31	65	ACH2
ACH3	30	64	AIGND
AIGND	29	63	ACH11
ACH4	28	62	AISENSE
AIGND	27	61	ACH12
ACH13	26	60	ACH5
ACH6	25	59	AIGND
AIGND	24	58	ACH14
ACH15	23	57	ACH7
DAC0OUT ¹	22	56	AIGND
DAC1OUT ¹	21	55	AOGND
RESERVED	20	54	AOGND
DIO4	19	53	DGND
DGND	18	52	DIO0
DIO1	17	51	DIO5
DIO6	16	50	DGND
DGND	15	49	DIO2
+5V	14	48	DIO7
DGND	13	47	DIO3
DGND	12	46	SCANCLK
PF10/TRIG1	11	45	EXTSTROBE*
PF11/TRIG2	10	44	DGND
DGND	9	43	PF12/CONVERT*
+5V	8	42	PF13/GPCTR1_SOURCE
DGND	7	41	PF14/GPCTR1_GATE
PF15/UPDATE*	6	40	GPCTR1_OUT
PF16/WFTRIG	5	39	DGND
DGND	4	38	PF17/STARTSCAN
PF19/GPCTR0_GATE	3	37	PF18/GPCTR0_SOURCE
GPCTR0_OUT	2	36	DGND
FREQ_OUT	1	35	DGND

¹ Not available on the NI 6034E

Figure B-1. 68-Pin E Series Connector Pin Assignments

Figure B-2 shows the pin assignments for the 50-pin E Series connector. This connector is available when you use the SH6850 or R6850 cable assemblies.

AIGND	1	2	AIGND
ACH0	3	4	ACH8
ACH1	5	6	ACH9
ACH2	7	8	ACH10
ACH3	9	10	ACH11
ACH4	11	12	ACH12
ACH5	13	14	ACH13
ACH6	15	16	ACH14
ACH7	17	18	ACH15
AISENSE	19	20	DAC0OUT ¹
DAC1OUT ¹	21	22	RESERVED
AOGND	23	24	DGND
DIO0	25	26	DIO4
DIO1	27	28	DIO5
DIO2	29	30	DIO6
DIO3	31	32	DIO7
DGND	33	34	+5V
+5V	35	36	SCANCLK
EXTSTROBE*	37	38	PFI0/TRIG1
PFI1/TRIG2	39	40	PFI2/CONVERT*
PFI3/GPCTR1_SOURCE	41	42	PFI4/GPCTR1_GATE
GPCTR1_OUT	43	44	PFI5/UPDATE*
PFI6/WFTRIG	45	46	PFI7/STARTSCAN
PFI8/GPCTR0_SOURCE	47	48	PFI9/GPCTR0_GATE
GPCTR0_OUT	49	50	FREQ_OUT

¹ AO is not available on the NI 6034E.

Figure B-2. 50-Pin E Series Connector Pin Assignments



Common Questions

This appendix contains a list of commonly asked questions and their answers relating to usage and special features of the NI 6034E/6035E/6036E.

General Information

What is the DAQ-STC?

The DAQ-STC is the system timing control application-specific integrated circuit (ASIC) designed by NI and is the backbone of the NI 6034E/6035E/6036E. The DAQ-STC contains seven 24-bit counters and three 16-bit counters. The counters are divided into the following three groups:

- AI—two 24-bit, two 16-bit counters
- AO—three 24-bit, one 16-bit counters
- GPCTR functions—two 24-bit counters

The groups can be independently configured with timing resolutions of 50 ns or 10 μ s. With the DAQ-STC, you can interconnect a wide variety of internal timing signals to other internal blocks. The interconnection scheme is quite flexible and completely software configurable. New capabilities such as buffered pulse generation, equivalent time sampling, and seamless changing of the sampling rate are possible.

What does sampling rate mean to me?

Sampling rate is the fastest you can acquire data on the NI 6034E/6035E/6036E and still achieve accurate results. For example, these devices have a sampling rate of 200 kS/s. This sampling rate is aggregate: one channel at 200 kS/s or two channels at 100 kS/s per channel.

What type of 5 V protection does the NI 6034E/6035E/6036E have?

The NI 6034E/6035E/6036E has 5 V lines equipped with a self-resetting 1 A fuse. The PCMCIA cards have 5 V lines equipped with a self-resetting 0.75 A fuse.

How do I use the NI 6034E/6035E/6036E with the NI-DAQ C API?

The *NI-DAQ User Manual* describes the general programming flow and provides example code for using the NI-DAQ API. For a list of functions that support the NI 6034E/6035E/6036E, you can refer to the *NI-DAQ Online Help* (for NI-DAQ version 6.7 or later) or the *NI-DAQ Function Reference Manual* (for NI-DAQ version 6.6 or earlier).

You can download the *NI-DAQ User Manual* and the *NI-DAQ Function Reference Manual* from ni.com/manuals. You can access the *NI-DAQ Online Help* by selecting **Start»Programs»National Instruments»NI-DAQ»NI-DAQ Help**. Refer to ni.com/downloads to download the version of NI-DAQ that your application requires.

Installing and Configuring the NI 6034E/6035E/6036E

How do I set the base address for the NI 6034E/6035E/6036E?

The PCI bus protocol automatically assigns the base address of the NI 6034E/6035E/6036E.

What jumpers should I be aware of when configuring my E Series device?

The NI 6034E/6035E/6036E is jumperless and switchless.

Which NI document should I read first to get started using DAQ software?

The *DAQ Quick Start Guide* and the NI-DAQ or application software release notes documentation are good places to start.

What version of NI-DAQ must I have to use the NI 6034E/6035E/6036E?

For the NI 6034E and NI 6035E you must have NI-DAQ version 6.6 or later, and for the NI 6036E you must have NI-DAQ version 6.9.2 or later.

What is the best way to test the NI 6034E/6035E/6036E without programming the device?

If you are using Windows, Measurement and Automation Explorer (MAX) has a Test Panel option that is available by selecting **Devices and Interfaces** and then selecting the device. The Test Panels are excellent tools for performing simple functional tests of the device, such as AI, DIO, and counter/timer tests. If you are using the Mac OS, the NI-DAQ Calibration Utility provides the same functionality.

The DAQ device is not returning measurements accurate to the published specifications. What's wrong?

Check the onboard device temperature reading when the device is in its operating environment. To check the onboard device temperature, complete the following steps.

1. Launch MAX by clicking **Start»Programs»National Instruments»Measurement and Automation Explorer**.
2. Start the test panel for the device by expanding the **Devices and Interfaces** section, right-clicking the device, and selecting the **Test Panel** option.
3. Type `_devtemp` on any AI channel.
4. Multiply the average measured value by 100 and subtract 50. This is the temperature in Celsius read by the onboard temperature sensor.

If the temperature is above 70 degrees Celsius, the board may not calibrate because some board components may be operating outside their intended range. The calDACs can only correct for errors when the operating temperature is between 0 and 70 degrees Celsius.

Analog Input and Output

I am using the device in DIFF input mode, and I have connected a differential input signal, but my readings are random and drift rapidly. What is wrong?

Check the ground reference connections. The signal may be referenced to a level that is considered *floating* with reference to the device ground reference. Even if you are in DIFF mode, the signal *must* still be referenced to the same ground level as the device reference. You can use one of various methods to achieve ground reference while maintaining a high common-mode rejection ratio (CMRR). Refer to Chapter 4, [Connecting Signals](#), for more information.

I am seeing crosstalk or ghost voltages when sampling multiple channels. What does this mean?

You may be experiencing a phenomenon called charge injection. Charge injection occurs when you sample a series of high-output impedance sources with a multiplexer. Multiplexers contain switches, usually made of switched capacitors. When one channel is selected in a multiplexer, those capacitors accumulate charge. When the next channel is selected, the accumulated charge leaks backward through that channel. If the output impedance of the source connected to the second channel is high enough, the resulting reading can somewhat reflect the voltage trends in the first channel.

To solve this problem, you must either use a voltage follower (op-amp with unity gain) for each high-impedance source before connecting to the DAQ device or decrease the sample rate.

Another common cause of channel crosstalk is caused by sampling multiple channels at various gains. In this situation, the settling times may increase. For more information on charge injection and sampling channels at different gains, refer to the [Scanning Multiple Channels](#) section of Chapter 3, [Hardware Overview](#).

I am using the DACs to generate a waveform, but I discovered with a digital oscilloscope that there are glitches on the output signal. Is this normal?

When it switches from one voltage to another, any DAC produces glitches due to released charges. The largest glitches occur when the most significant bit (MSB) of the D/A code switches. You can build a lowpass deglitching filter to remove some of these glitches, depending on the frequency and nature of your output signal.

Can I synchronize a one-channel AI data acquisition with a one-channel AO waveform generation on the NI PCI-6034E/6035E/6036E?

Yes. One way to accomplish synchronization is to use the waveform generation timing pulses to control the AI data acquisition. To do this, follow steps 1 through 4, in addition to the usual steps for data acquisition and waveform generation configuration.

1. Enable the PFI5 line for output, as follows:
 - If you are using NI-DAQ, call `Select_Signal(deviceNumber, ND_PFI_5, ND_OUT_UPDATE, ND_HIGH_TO_LOW)`.

- If you are using LabVIEW, call the Route Signal VI with signal name set to PFI5 and signal source set to AO Update.
2. Set up data acquisition timing so that the timing signal for A/D conversion comes from PFI5, as follows:
 - If you are using NI-DAQ, call `Select_Signal(deviceNumber, ND_IN_CONVERT, ND_PFI_5, ND_HIGH_TO_LOW)`.
 - If you are using LabVIEW, call the AI Clock Config VI with clock source code set to PFI pin, high to low, and clock source string set to 5.
 3. Initiate AI data acquisition, which starts only when the AO waveform generation starts.
 4. Initiate AO waveform generation.

Can I programmatically enable different channels on an E Series device to acquire in different modes? For example, can channel 0 be in DIFF mode and channel 1 be in RSE mode?

Different channels on E Series devices can be enabled to acquire in different modes. However, different pairs of channels are used in different modes. In the configuration mentioned in the question above, ACH0 and ACH8 would be configured in DIFF mode, and ACH1 and AIGND would be configured in RSE mode. In this configuration, ACH8 could not be used in a single-ended configuration.

To enable multi-mode scanning in LabVIEW, you would use the coupling & input config cluster input of the AI Config VI. This input has a one-to-one correspondence with the channels array input of the AI Config VI. Therefore, you must list all channels either individually or in groups of channels with the same input configuration. For example, if you want channel 0 to be DIFF and channels 1 and 2 to be RSE, Figure C-1 demonstrates how to program this configuration in LabVIEW.

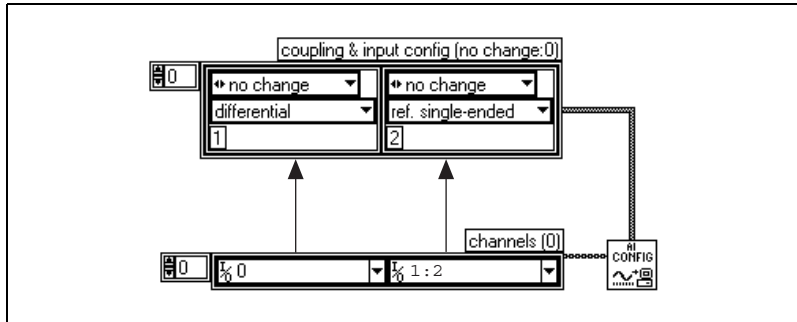

Figure C-1. Configuring Channels for Different Acquisition Modes in LabVIEW

To enable multi-mode scanning when using NI-DAQ function calls, call the `AI_Configure` function for each channel.

How can I use the STARTSCAN and CONVERT* signals on the NI 634E/6035E/6036E to sample AI channels?

E Series devices employ both the STARTSCAN and CONVERT* signals to perform interval sampling. STARTSCAN, output by the DAQ-STC, controls the *scan interval* (1/scan interval = scan rate) shown in Figure C-2.

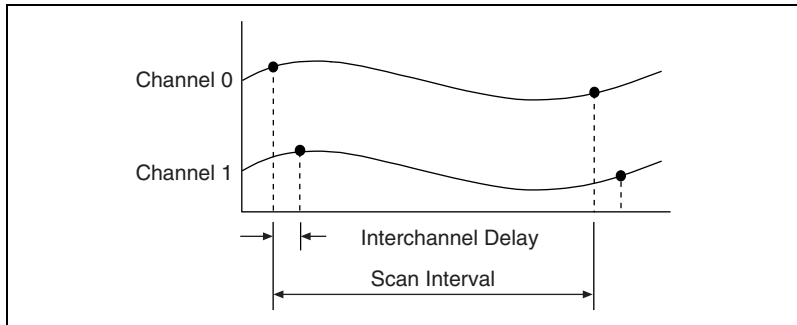

Figure C-2. Interchannel Delay and Scan Interval

CONVERT* controls the *interchannel delay* (1/interchannel delay = sampling rate). This method allows multiple channels to be sampled relatively quickly in relationship to the overall scan rate. The effect of this method is a pseudo-simultaneous effect with a fixed delay between channels.

Timing and Digital I/O

What types of triggering can be hardware-implemented on the NI 6034E/6035E/6036E?

Digital triggering is hardware-supported on the NI 6034E/6035E/6036E.

I am using one of the general-purpose counter/timers on my device, but I do not see the counter/timer output on the I/O connector. Why?

If you are using NI-DAQ or LabWindows/CVI, you must configure the output line to output the signal to the I/O connector. Use the `Select_Signal` function in NI-DAQ to configure the output line. By default, all timing I/O lines except EXTSTROBE* are high-impedance.

What are the PFIs and how do I configure these lines?

PFIs are programmable function inputs. These lines serve as connections to virtually all internal timing signals.

If you are using NI-DAQ or LabWindows/CVI, use the `Select_Signal` function to route internal signals to the I/O connector, route external signals to internal timing sources, or tie internal timing signals together.

If you are using NI-DAQ with LabVIEW and you want to connect external signal sources to the PFI lines, you can use AI Clock Config, AI Trigger Config, AO Clock Config, AO Trigger and Gate Config, CTR Mode Config, and CTR Pulse Config advanced-level VIs to indicate which function the connected signal serves. Use the Route Signal VI to enable the PFI lines to output internal signals.



Caution If you enable a PFI line for output, do *not* connect any external signal source to it; if you do, you can damage the device, the computer, and the connected equipment.

Table C-1 shows the corresponding hardware signal names and software signal names in LabVIEW and NI-DAQ.

Table C-1. Signal Name Equivalencies

Hardware Signal Name	LabVIEW Route Signal	NI-DAQ Select_Signal
TRIG1	AI Start Trigger	ND_IN_START_TRIGGER
TRIG2	AI Stop Trigger	ND_IN_STOP_TRIGGER
STARTSCAN	AI Scan Start	ND_IN_SCAN_START

Table C-1. Signal Name Equivalencies (Continued)

Hardware Signal Name	LabVIEW Route Signal	NI-DAQ Select_Signal
SISOURCE	—	ND_IN_SCAN_CLOCK_TIMEBASE
CONVERT*	AI Convert	ND_IN_CONVERT
AIGATE	—	ND_IN_EXTERNAL_GATE
WFTRIG	AO Start Trigger	ND_OUT_START_TRIGGER
UPDATE*	AO Update	ND_OUT_UPDATE
UISOURCE	—	ND_OUT_UPDATE_CLOCK_TIMEBASE
AOGATE	—	ND_OUT_EXTERNAL_GATE

What are the power-on states of the PFI and DIO lines on the I/O connector?

At system power-on and reset, both the PFI and DIO lines are set to high-impedance by the hardware. This setting means that the device circuitry is not actively driving the output either high or low. However, these lines may have pull-up or pull-down resistors connected to them as shown in Table 4-3, *I/O Signal Summary for the NI 6034E/6035E/6036E*. These resistors weakly pull the output to either a logic-high or logic-low state. For example, DIO<0> is in the high-impedance state after power on, and Table 4-3, *I/O Signal Summary for the NI 6034E/6035E/6036E*, shows the 50 k Ω pull-up resistor. This pull-up resistor sets the DIO<0> pin to a logic high when the output is in a high-impedance state.

Technical Support and Professional Services

Visit the following sections of the National Instruments Web site at ni.com for technical support and professional services:

- **Support**—Online technical support resources include the following:
 - **Self-Help Resources**—For immediate answers and solutions, visit our extensive library of technical support resources available in English, Japanese, and Spanish at ni.com/support. These resources are available for most products at no cost to registered users and include software drivers and updates, a KnowledgeBase, product manuals, step-by-step troubleshooting wizards, hardware schematics and conformity documentation, example code, tutorials and application notes, instrument drivers, discussion forums, a measurement glossary, and so on.
 - **Assisted Support Options**—Contact NI engineers and other measurement and automation professionals by visiting ni.com/ask. Our online system helps you define your question and connects you to the experts by phone, discussion forum, or email.
- **Training**—Visit ni.com/custed for self-paced tutorials, videos, and interactive CDs. You also can register for instructor-led, hands-on courses at locations around the world.
- **System Integration**—If you have time constraints, limited in-house technical resources, or other project challenges, NI Alliance Program members can help. To learn more, call your local NI office or visit ni.com/alliance.

If you searched ni.com and could not find the answers you need, contact your local office or NI corporate headquarters. Phone numbers for our worldwide offices are listed at the front of this manual. You also can visit the Worldwide Offices section of ni.com/niglobal to access the branch office Web sites, which provide up-to-date contact information, support phone numbers, email addresses, and current events.

Glossary

Prefix	Meanings	Value
p-	pico	10^{-12}
n-	nano-	10^{-9}
μ -	micro-	10^{-6}
m-	milli-	10^{-3}
k-	kilo-	10^3
M-	mega-	10^6
G-	giga-	10^9

Symbols

%	percent
+	positive of, or plus
-	negative of, or minus
/	per
°	degree
Ω	ohm

A

A	amperes
A/D	analog-to-digital
AC	alternating current
ACH	analog input channel signal

ADC	analog-to-digital converter—an electronic device, often an integrated circuit, that converts an analog voltage to a digital number
ADE	application development environment
AI	analog input
AIGATE	analog input gate signal
AIGND	analog input ground signal
AISENSE	analog input sense signal
ANSI	American National Standards Institute
AO	analog output
AOGND	analog output ground signal

B

bandwidth	the range of frequencies present in a signal, or the range of frequencies to which a measuring device can respond
base address	a memory address that serves as the starting address for programmable registers. All other addresses are located by adding to the base address.
bipolar	a signal range that includes both positive and negative values (for example, -5 to +5 V)
breakdown voltage	the voltage high enough to cause breakdown of optical isolation, semiconductors, or dielectric materials. <i>See also</i> working voltage .
bus	the group of conductors that interconnect individual circuitry in a computer. Typically, a bus is the expansion vehicle to which I/O or other devices are connected. Examples of PC buses are the ISA and PCI bus.
bus master	a type of a plug-in device or controller with the ability to read and write devices on the computer bus

C

C	Celsius
CalDAC	calibration DAC
CH	channel—pin or wire lead to which you apply or from which you read the analog or digital signal. Analog signals can be single-ended or differential. For digital signals, you group channels to form ports. Ports usually consist of either four or eight digital channels.
channel clock	the clock controlling the time interval between individual channel sampling within a scan. Devices with simultaneous sampling do not have this clock.
channel rate	reciprocal of the interchannel delay
charge injection	an event that occurs when scanning high-impedance signals where the analog input multiplexer injects a small amount of charge into each signal source when that source is selected.
CMOS	complementary metal-oxide semiconductor
CMRR	common-mode rejection ratio—a measure of an instrument's ability to reject interference from a common-mode signal, usually expressed in decibels (dB)
common-mode signal	any voltage present at the instrumentation amplifier inputs with respect to amplifier ground
CONVERT*	convert signal
counter/timer	a circuit that counts external pulses or clock pulses (timing)
crosstalk	an unwanted signal on one channel due to an input on a different channel
CTR	counter

D

D/A	digital-to-analog
DAC	digital-to-analog converter—an electronic device, often an integrated circuit, that converts a digital number into a corresponding analog voltage or current

DAC0OUT	analog channel 0 output signal
DAC1OUT	analog channel 1 output signal
DAQ	data acquisition—(1) collecting and measuring electrical signals from sensors, transducers, and test probes or fixtures and inputting them to a computer for processing; (2) collecting and measuring the same kinds of electrical signals with A/D and/or DIO devices plugged into a computer, and possibly generating control signals with D/A and/or DIO devices in the same computer
DAQ-STC	data acquisition system timing controller chip
dB	decibel—the unit for expressing a logarithmic measure of the ratio of two signal levels: $dB = 20\log_{10} V1/V2$, for signals in volts
DC	direct current
DGND	digital ground signal
DIFF	differential mode
differential input	an analog input consisting of two terminals, both of which are isolated from computer ground, whose difference is measured
DIO	digital input/output
dithering	the addition of Gaussian noise to an analog input signal
DMA	direct memory access—a method by which data can be transferred to/from computer memory from/to a device or memory on the bus while the processor does something else. DMA is the fastest method of transferring data to/from computer memory.
DNL	differential nonlinearity—a measure in least significant bit of the worst-case deviation of code widths from their ideal value of 1 LSB
DO	digital output
driver	software that controls a specific hardware device such as a DAQ device or a GPIB interface board

E

EEPROM	electrically erasable programmable read-only memory—ROM that can be erased with an electrical signal and reprogrammed
EMC	electromagnetic compatibility
EMI	electromagnetic interference—defines unwanted electromagnetic radiation from a device, which could interfere with desired signals in test or communication equipment
ESD	electrostatic discharge
EXTSTROBE	external strobe signal

F

FIFO	first-in first-out memory buffer—the first data stored is the first data sent to the acceptor. FIFOs are often used on DAQ devices to temporarily store incoming or outgoing data until that data can be retrieved or output. For example, an analog input FIFO stores the results of A/D conversions until the data can be retrieved into system memory, a process that requires the servicing of interrupts and often the programming of the DMA controller. This process can take several milliseconds in some cases. During this time, data accumulates in the FIFO for future retrieval. With a larger FIFO, longer latencies can be tolerated. In the case of analog output, a FIFO permits faster update rates, because the waveform data can be stored on the FIFO ahead of time. This again reduces the effect of latencies associated with getting the data from system memory to the DAQ device.
floating signal sources	signal sources with voltage signals that are not connected to an absolute reference or system ground. Also called nonreferenced signal sources. Some common example of floating signal sources are batteries, transformers, or thermocouples.
FREQ_OUT	frequency output signal
ft	feet

G

g	grams
gain	the factor by which a signal is amplified, sometimes expressed in decibels
gain accuracy	a measure of deviation of the gain of an amplifier from the ideal gain
glitch	an unwanted momentary deviation from a desired signal
GPCTR	general purpose counter
GPCTR0_GATE	general purpose counter 0 gate signal
GPCTR0_OUT	general purpose counter 0 output signal
GPCTR0_SOURCE	general purpose counter 0 clock source signal
GPCTR0_UP_DOWN	general purpose counter 0 up down
GPCTR1_GATE	general purpose counter 1 gate signal
GPCTR1_OUT	general purpose counter 1 output signal
GPCTR1_SOURCE	general purpose counter 1 clock source signal
GPCTR1_UP_DOWN	general purpose counter 1 up down
grounded measurement system	<i>See</i> referenced single-ended configuration.

H

h	hour
Hz	hertz—the number of scans read or updates written per second

I

I/O	input/output—the transfer of data to/from a computer system involving communications channels, operator interface devices, and/or data acquisition and control interfaces
in.	inches
INL	integral nonlinearity—a measure in LSB of the worst-case deviation from the ideal A/D or D/A transfer characteristic of the analog I/O circuitry
input bias current	the current that flows into the inputs of a circuit
input impedance	the resistance and capacitance between the input terminals of a circuit
input offset current	the difference in the input bias currents of the two inputs of an instrumentation amplifier
instrumentation amplifier	a circuit whose output voltage with respect to ground is proportional to the difference between the voltages at its two high impedance inputs
interchannel delay	amount of time that passes between sampling consecutive channels. The interchannel delay must be short enough to allow sampling of all the channels in the channel list, within the scan interval. The greater the interchannel delay, the more time the PGIA is allowed to settle before the next channel is sampled. The interchannel delay is regulated by CONVERT*.
interrupt	a computer signal indicating that the CPU should suspend its current task to service a designated activity
I_{OH}	current, output high
I_{OL}	current, output low

K

k	kilo—the standard metric prefix for 1,000, or 10^3 , used with units of measure such as volts, hertz, and meters
kS	1,000 samples

L

LabVIEW	Laboratory Virtual Instrument Engineering Workbench—a program development application based on the programming language G and used commonly for test and measurement purposes
LED	light-emitting diode
library	a file containing compiled object modules, each comprised of one or more functions, that can be linked to other object modules that make use of these functions. NIDAQMSC.LIB is a library that contains NI-DAQ functions. The NI-DAQ function set is broken down into object modules so that only the object modules that are relevant to your application are linked in, while those object modules that are not relevant are not linked.
linearity	the adherence of device response to the equation $R = KS$, where R = response, S = stimulus, and K = a constant
LSB	least significant bit

M

MAX	Measurement and Automation Explorer—National Instruments software for configuring devices and channels.
MITE	MXI Interface to Everything—a custom ASIC designed by National Instruments that implements the PCI bus interface. The MITE supports bus mastering for high-speed data transfers over the PCI bus.
MSB	most significant bit
mux	multiplexer—a switching device with multiple inputs that sequentially connects each of its inputs to its output, typically at high speeds, in order to measure several signals with a single analog input channel

N

NI	National Instruments
NI-DAQ	National Instruments driver software for DAQ hardware

noise an undesirable electrical signal—noise comes from external sources such as the AC power line, motors, generators, transformers, fluorescent lights, soldering irons, CRT displays, computers, electrical storms, welders, radio transmitters, and internal sources such as semiconductors, resistors, and capacitors. Noise corrupts signals you are trying to send or receive.

NRSE nonreferenced single-ended mode—all measurements are made with respect to a common (NRSE) measurement system reference, but the voltage at this reference can vary with respect to the measurement system ground.

O

OUT output pin—a counter output pin where the counter can generate various TTL pulse waveforms

P

PC Card a credit-card-sized expansion card that fits in a PCMCIA slot, often referred to as a PCMCIA card

PCI Peripheral Component Interconnect—a high-performance expansion bus architecture originally developed by Intel to replace ISA and EISA. It is achieving widespread acceptance as a standard for PCs and work-stations; it offers a theoretical maximum transfer rate of 132 Mbytes/s.

PCMCIA PCMCIA is an international standards body and trade association that promotes the inter operability of PC cards. It devised the standard for the credit card-size adapter cards used in many notebook computers. Three card thicknesses are defined: Type I, II, and III.

PFI programmable function input

PFI0/TRIG1 PFI0/trigger 1

PFI1/TRIG2 PFI1/trigger 2

PFI2/CONVERT* PFI2/convert

PFI3/GPCTR1_SOURCE PFI3/general purpose counter 1 source

PFI4/GPCTR1_GATE PFI4/general purpose counter 1 gate

PFI5/UPDATE*	PFI5/update
PFI6/WFTRIG	PFI6/waveform trigger
PFI7/STARTSCAN	PFI7/start of scan
PFI8/GPCTR0_SOURCE	PFI8/general purpose counter 0 source
PFI9/GPCTR0_GATE	PFI9/general purpose counter 0 gate
PGIA	programmable gain instrumentation amplifier
port	(1) a communications connection on a computer or a remote controller; (2) a digital port, consisting of four or eight lines of digital input and/or output
ppm	parts per million
pu	pull up

Q

quantization error	the inherent uncertainty in digitizing an analog value due to the finite resolution of the conversion process
--------------------	---

R

radix	the base of a numbering system, for example, “base 10”
referenced single-ended configuration	RSE—all measurements are made with respect to a common reference measurement system or ground; also called a grounded measurement system
relative accuracy	a measure in LSB of the accuracy of an ADC. It includes all non-linearity and quantization errors. It does not include offset and gain errors of the circuitry feeding the ADC.
resolution	the smallest signal increment that can be detected by a measurement system. Resolution can be expressed in bits, in proportions, or in percent of full scale. For example, a system has 12-bit resolution, one part in 4,096 resolution, and 0.0244% of full scale.

ribbon cable	a flat cable in which the wires are lined up, not bunched together
rise time	the difference in time between the 10% and 90% points of a system's step response
rms	root mean square—the square root of the average value of the square of the instantaneous signal amplitude; a measure of signal amplitude
RSE	<i>See</i> referenced single-ended configuration.
RTD	resistance temperature detector
RTSI bus	real-time system integration bus—the National Instruments timing bus that connects DAQ devices directly, for precise synchronization of functions. For PCI devices, the connection is made by means of connectors on top of the device.
S	
s	seconds
S	samples
S/s	samples per second—used to express the rate at which a DAQ device samples an analog signal
sample counter	the clock that counts the output of the channel clock, in other words, the number of samples taken. On devices with simultaneous sampling, this counter counts the output of the scan clock and hence the number of scans.
scan	one or more analog or digital input samples. Typically, the number of input samples in a scan is equal to the number of channels in the input group. For example, one pulse from the scan clock produces one scan which acquires one new sample from every analog input channel in the group.
scan clock	the clock controlling the time interval between scans.
scan interval	controls how often a scan is initialized. The scan interval is regulated by STARTSCAN.
scan rate	reciprocal of the scan interval
SCANCLK	scan clock signal

SCXI	Signal Conditioning eXtensions for Instrumentation—the National Instruments product line for conditioning low-level signals within an external chassis near sensors so only high-level signals are sent to DAQ devices in the noisy PC environment
self-calibrating	a property of a DAQ device that has an extremely stable onboard reference and calibrates its own A/D and D/A circuits without manual adjustments by the user
settling time	the amount of time required for a voltage to reach its final value within specified limits
signal conditioning	the manipulation of signals to prepare them for digitizing
SISOURCE	SI counter clock signal
software trigger	a programmed event that triggers an event such as data acquisition
SOURCE	source signal
STARTSCAN	start scan signal
STC	system timing controller
T	
TC	terminal count—the highest value of a counter
THD	total harmonic distortion—the ratio of the total rms signal due to harmonic distortion to the overall rms signal, in decibel or a percentage
TIO	timing input/output
TRIG	trigger signal
trigger	any event that causes or starts some form of data capture
TTL	transistor-transistor logic—a digital circuit composed of bipolar transistors wired in a certain manner
two's complement	given a number x expressed in base 2 with n digits to the left of the radix point, the (base 2) number $2n - x$

U

UI	update interval
UISOURCE	update interval counter clock signal
update	the output equivalent of a scan. One or more analog or digital output samples. Typically, the number of output samples in an update is equal to the number of channels in the output group. For example, one pulse from the update clock produces one update which sends one new sample to every analog output channel in the group.
update rate	the number of output updates per second

V

V	volts
V_{CC}	positive supply voltage
VDC	volts direct current
VI	virtual instrument—(1) a combination of hardware and/or software elements, typically used with a PC, that has the functionality of a classic stand-alone instrument; (2) a LabVIEW software module (VI), which consists of a front panel user interface and a block diagram program
V_{IH}	volts, input high
V_{IL}	volts, input low
V_{in}	volts in
V_m	measured voltage
V_{OH}	volts, output high
V_{OL}	volts, output low
V_{rms}	volts, root mean square

W

waveform	multiple voltage readings taken at a specific sampling rate
WFTRIG	waveform generation trigger signal
working voltage	the highest voltage that should be applied to a product in normal use, normally well under the breakdown voltage for safety margin. <i>See also</i> breakdown voltage .

Index

Symbols

- +5 V signal
 - description (table), 4-3
 - self-resetting fuse, 4-20, C-2

Numerics

- 50-pin E Series connector pin assignments (figure), B-4
- 68-pin connector pin assignments (figure), 4-2, B-3

A

- ACH<0..15> signals
 - description (table), 4-3
 - differential connections for nonreferenced signals (figure), 4-12
 - differential input connections for ground-referenced signals (figure), 4-14
 - signal summary (table), 4-5
 - single-ended input connections for ground-referenced signals (figure), 4-17
 - single-ended input connections for nonreferenced or floating signals (figure), 4-16
- AIGATE signal
 - RTSI bus signal connections (figure), 3-8
 - timing connections, 4-29
- AIGND signal
 - description (table), 4-3
 - differential input connections for ground-referenced signals (figure), 4-14
 - differential input connections for nonreferenced signals (figure), 4-12
 - signal summary (table), 4-5
 - single-ended input connections for ground-referenced signals (figure), 4-17
 - single-ended input connections for nonreferenced or floating signals (figure), 4-16
- AISENSE signal
 - description (table), 4-3
 - differential connections for nonreferenced signals (figure), 4-12
 - differential input connections for ground-referenced signals (figure), 4-14
 - signal summary (table), 4-5
 - single-ended input connections for ground-referenced signals (figure), 4-17
 - single-ended input connections for nonreferenced or floating signals (figure), 4-16
- analog input
 - input mode, 3-2
 - input range, 3-3
 - questions about, C-3
 - specifications
 - accuracy information, A-2, A-12
 - amplifier characteristics, A-3, A-13
 - dynamic characteristics, A-3, A-13
 - input characteristics, A-1, A-11
 - stability, A-4, A-14
 - transfer characteristics, A-2, A-12
 - types of signal sources
 - floating signal sources, 4-6
 - ground-referenced signal sources, 4-7
- analog input modes
 - available input configurations (table), 4-10
 - common-mode signal rejection considerations, 4-17

- differential input mode
 - ground-referenced signal sources, 4-14
 - nonreferenced or floating signal sources, 4-12
 - overview, 4-11
- exceeding common-mode input ranges (caution), 4-8
- single-ended modes
 - floating signal sources (RSE input mode), 4-16
 - grounded signal sources (NRSE input mode), 4-16
 - overview, 4-15
- analog output
 - calibration considerations, 5-3
 - glitch operation, 3-5
 - number of channels, 3-5
 - output range, 3-5
 - questions about, C-3
 - signal connections, 4-17
 - specifications
 - accuracy information, A-5, A-15
 - dynamic characteristics, A-7, A-16
 - output characteristics, A-4, A-14
 - stability, A-7, A-16
 - transfer characteristics, A-5, A-15
 - voltage output, A-6, A-15
- AOGND signal
 - analog output connections (figure), 4-18
 - description (table), 4-3
 - signal summary (table), 4-5

B

- bipolar input range, 3-3
- block diagrams
 - DAQCard-6036E, 3-2
 - NI PCI-6034E/6035E/6036E, 3-1

bus

- PCI
 - configuration, 2-2
 - PCI Local Bus Specification Revision 2.2, 2-2
 - system overview, 1-1
- PCMCIA
 - configuration, 2-2
- RTSI
 - device and RTSI clocks, 3-7
 - overview, 1-1
 - PCI RTSI bus signal connection (figure), 3-8
 - RTSI triggers, 3-8
 - timing signal routing, 3-5

C

- cables
 - See also* I/O connectors
 - field wiring considerations, 4-40
 - optional equipment, 1-4
- calibration
 - adjusting gain error, 5-3
 - external calibration, 5-2
 - loading calibration constants, 5-1
 - self-calibration, 5-2
 - specifications, A-9, A-17
- charge injection, 3-4
- clocks, device and RTSI, 3-7
- commonly asked questions. *See* questions and answers
- common-mode signal rejection considerations, 4-17
- configuring
 - hardware, 2-2
 - questions about, C-2
- connecting signals
 - analog output, 4-17
 - digital I/O, 4-19
- contacting National Instruments, D-1

CONVERT* signal
 See also PFI2/CONVERT* signal
 input timing (figure), 4-28
 output timing (figure), 4-28
 RTSI bus signal connections (figure), 3-8
 timing connections, 4-28
 typical posttriggered acquisition
 (figure), 4-22
 typical pretriggered acquisition
 (figure), 4-23
 custom cabling
 cables
 custom, B-1
 customer
 education, D-1
 professional services, D-1
 technical support, D-1

D

DAC0OUT signal
 analog output connections (figure), 4-18
 description (table), 4-3
 signal summary (table), 4-5
 DAC1OUT signal
 analog output connections (figure), 4-18
 description (table), 4-3
 signal summary (table), 4-5
 DAQ timing connections
 AIGATE signal, 4-29
 CONVERT* signal, 4-28
 EXTSTROBE* signal, 4-31
 SCANCLK signal, 4-30
 SISOURCE signal, 4-29
 STARTSCAN signal, 4-25
 TRIG1 signal, 4-23
 TRIG2 signal, 4-24
 typical posttriggered acquisition
 (figure), 4-22
 typical pretriggered acquisition
 (figure), 4-23

DAQ-STC system timing controller
 overview, 1-1
 questions about, C-1
 DGND signal
 description (table), 4-3
 digital I/O connections (figure), 4-19
 signal summary (table), 4-5
 timing I/O connections (figure), 4-21
 diagnostic resources, D-1
 differential (DIFF) input mode
 description (table), 3-3
 differential connections
 ground-referenced signal
 sources, 4-14
 nonreferenced or floating signal
 sources, 4-12
 when to use, 4-11
 questions about, C-3
 recommended configuration
 (figure), 4-10
 digital I/O
 See also DIO<0..7> signals; DGND
 signals
 connecting signals, 4-19
 overview, 3-5
 questions about, C-7
 specifications, A-8, A-16
 digital trigger
 questions about, C-7
 specifications, A-9, A-17
 DIO<0..7> signals
 description (table), 4-3
 digital I/O connections (figure), 4-19
 signal summary (table), 4-5
 specifications, A-8, A-16
 documentation
 online library, D-1
 drivers
 instrument, D-1
 software, D-1

E

EEPROM storage of calibration constants, 5-1
 electromagnetic compatibility specifications, A-11, A-19
 environmental noise, 4-40
 environmental specifications, A-10, A-18
 equipment
 optional, 1-4
 what you need to get started, 1-2
 example code, D-1
 external calibration, 5-2
 EXTSTROBE* signal
 description (table), 4-3
 signal summary (table), 4-5
 timing connections, 4-31
 timing diagram, 4-31

F

field wiring considerations, 4-40
 floating signal sources
 description, 4-6
 differential connections, 4-11, 4-12
 single-ended connections (RSE input mode), 4-16
 FREQ_OUT signal
 description (table), 4-5
 signal summary (table), 4-6
 timing connections, 4-40
 frequently asked questions, D-1
 See also questions and answers
 fuse, self-resetting, 4-20, C-2

G

gain error, adjusting, 5-3
 general-purpose timing signal connections
 FREQ_OUT signal, 4-40
 GPCTR0_GATE signal, 4-35
 GPCTR0_OUT signal, 4-36
 GPCTR0_SOURCE signal, 4-34

 GPCTR0_UP_DOWN signal, 4-36
 GPCTR1_GATE signal, 4-37
 GPCTR1_OUT signal, 4-38
 GPCTR1_SOURCE signal, 4-37
 GPCTR1_UP_DOWN signal, 4-39
 questions about, C-7
 getting started equipment, 1-2
 glitches
 analog output, 3-5
 waveform generation glitches, C-4
 GPCTR0_GATE signal
 See also PFI9/GPCTR0_GATE signal
 general-purpose counter timing summary (figure), 4-39
 RTSI bus signal connections (figure), 3-8
 timing connections, 4-35
 timing diagram, 4-36
 GPCTR0_OUT signal
 description (table), 4-5
 general-purpose counter timing summary (figure), 4-39
 RTSI bus signal connections (figure), 3-8
 signal summary (table), 4-6
 timing connections, 4-36
 timing diagram, 4-36
 GPCTR0_SOURCE signal
 See also PFI8/GPCTR0_SOURCE signal
 general-purpose counter timing summary (figure), 4-39
 relation to GPCTR0_OUT signal (figure), 4-36
 RTSI bus signal connections (figure), 3-8
 timing connections, 4-34
 timing diagram, 4-35
 GPCTR0_UP_DOWN signal
 digital I/O lines, 3-5
 timing connections, 4-36
 GPCTR1_GATE signal
 See also PFI4/GPCTR1_GATE signal
 general-purpose counter timing summary (figure), 4-39

- RTSI bus signal connections (figure), 3-8
- timing connections, 4-37
- timing diagram, 4-38
- GPCTR1_OUT signal
 - description (table), 4-4
 - general-purpose counter timing summary (figure), 4-39
 - signal summary (table), 4-6
 - timing connections, 4-38
 - timing diagram, 4-38
- GPCTR1_SOURCE signal
 - See also* PFI3/GPCTR1_SOURCE signal
 - general-purpose counter timing summary (figure), 4-39
 - RTSI bus signal connections (figure), 3-8
 - timing connections, 4-37
 - timing diagram, 4-37
- GPCTR1_UP_DOWN signal
 - digital I/O lines, 3-5
 - timing connections, 4-39
- ground-referenced signal sources
 - description, 4-7
 - differential connections, 4-14
 - recommended configuration (table), 4-10
 - single-ended connections (NRSE input mode), 4-16

H

- hardware
 - configuring, 2-2
 - installation, 2-1
 - unpacking the device, 1-5
 - hardware overview
 - analog input
 - input mode, 3-2
 - input range, 3-3
 - scanning multiple channels, 3-4
 - analog output
 - analog output glitch, 3-5
 - overview, 3-5
 - digital I/O, 3-5
 - timing signal routing, 3-5
 - device and RTSI clocks, 3-7
 - programmable function inputs, 3-7
 - RTSI triggers, 3-8
 - help
 - professional services, D-1
 - technical support, D-1
- ## I
- I/O connectors
 - See also* cables
 - connector details (table), 4-1
 - exceeding maximum ratings (caution), 4-1
 - optional connectors
 - 50-pin E Series connector pin assignments (figure), B-4
 - 68-pin E Series connector pin assignments (figure), B-3
 - description (table), B-2
 - pin assignments (figure), 4-2
 - signal descriptions (table), 4-3
 - signal summary (table), 4-5
 - input mode. *See* analog input modes
 - input range
 - exceeding common-mode input ranges (caution), 4-8
 - measurement precision (table), 3-3
 - overview, 3-3
 - installation
 - hardware, 2-1
 - questions about, C-2
 - safety information, 1-5
 - software, 2-1
 - unpacking the device, 1-5
 - instrument drivers, D-1

K

KnowledgeBase, D-1

L

LabVIEW application software, 1-3

loading calibration constants, 5-1

M

maximum working voltage specifications,
A-10, A-18

Measurement Studio application software, 1-3

multiple channel scanning, 3-4

N

National Instruments

ADE software

LabVIEW, 1-3

Measurement Studio, 1-3

VI Logger, 1-4

customer education, D-1

professional services, D-1

system integration services, D-1

technical support, D-1

worldwide offices, D-1

NI 6034E/6035E/6036E

See also hardware overview

block diagrams

DAQCard-6036E, 3-2

NI PCI-6034E/6035E/6036E, 3-1

features, 1-1

optional equipment, 1-4

questions about

analog input and output, C-3

general information, C-1

installing and configuring, C-2

timing and digital I/O, C-7

requirements for getting started, 1-2

safety information, 1-5

software programming choices, 1-2

unpacking the device, 1-5

NI-DAQ

overview, 1-2

questions about, C-2

noise, environmental, 4-40

nonreferenced single-ended (NRSE) mode

description (table), 3-3

recommended configuration (table), 4-10

single-ended connection

considerations, 4-15

single-ended connections for

ground-referenced signal sources, 4-16

O

online technical support, D-1

optional equipment, 1-4

P

PCI bus

configuration, 2-2

PCI Local Bus Specification

Revision, 2-2

PCI RTSI bus signal connection

(figure), 3-8

system overview, 1-1

PFI0/TRIG1 signal

See also TRIG1 signal

description (table), 4-3

signal summary (table), 4-5

timing I/O connections (figure), 4-21

PFI1/TRIG2 signal

See also TRIG2 signal

description (table), 4-4

signal summary (table), 4-5

PFI2/CONVERT* signal

See also CONVERT* signal

description (table), 4-4

- signal summary (table), 4-6
 - timing I/O connections (figure), 4-21
 - PFI3/GPCTR1_SOURCE signal
 - See also* GPCTR1_SOURCE signal
 - description (table), 4-4
 - signal summary (table), 4-6
 - PFI4/GPCTR1_GATE signal
 - See also* GPCTR1_GATE signal
 - description (table), 4-4
 - signal summary (table), 4-6
 - PFI5/UPDATE* signal
 - See also* UPDATE* signal
 - description (table), 4-4
 - signal summary (table), 4-6
 - PFI6/WFTRIG signal
 - See also* WFTRIG signal
 - description (table), 4-4
 - signal summary (table), 4-6
 - PFI7/STARTSCAN signal
 - See also* STARTSCAN signal
 - description (table), 4-4
 - signal summary (table), 4-6
 - PFI8/GPCTR0_SOURCE signal
 - See also* GPCTR0_SOURCE signal
 - description (table), 4-4
 - signal summary (table), 4-6
 - PFI9/GPCTR0_GATE signal
 - See also* GPCTR0_GATE signal
 - description (table), 4-4
 - signal summary (table), 4-6
 - PGIA
 - analog input modes, 4-8
 - diagram, 4-8
 - differential input connections
 - ground-referenced signals (figure), 4-14
 - nonreferenced signals (figure), 4-12
 - single-ended input connections
 - ground-referenced signals (figure), 4-17
 - nonreferenced or floating signals (figure), 4-16
 - phone technical support, D-1
 - physical specifications, A-10, A-18
 - posttriggered acquisition, typical (figure), 4-23
 - power connections, 4-20
 - power requirement specifications, A-10, A-18
 - power-on states of PFI and DIO lines, C-8
 - pretriggered acquisition, typical (figure), 4-22
 - professional services, D-1
 - programmable gain instrumentation amplifier.
 - See* PGIA
 - programming examples, D-1
- ## Q
- questions and answers
 - analog input and output, C-3
 - general information, C-1
 - installing and configuring, C-2
 - timing and digital I/O, C-7
- ## R
- Real-Time System Integration. *See* RTSI
 - referenced single-ended (RSE) mode
 - description (table), 3-3
 - recommended configuration (figure), 4-10
 - single-ended connection considerations, 4-15
 - single-ended connections for floating signal sources, 4-16
 - RTSI
 - device and RTSI clocks, 3-7
 - overview, 1-1
 - PCI RTSI bus signal connection (figure), 3-8
 - trigger lines specifications, A-9
 - triggers, 3-8

S

- safety information, 1-5
- safety specifications, A-10, A-19
- sampling rate, C-1
- scan counter
 - typical posttriggered acquisition (figure), 4-22
 - typical pretriggered acquisition (figure), 4-23
- SCANCLK signal
 - description (table), 4-3
 - signal summary (table), 4-5
 - timing connections, 4-30
 - timing diagram, 4-30
- scanning multiple channels, 3-4
- SCXI
 - overview, 1-1
- self-calibration, 5-2
- self-resetting fuse, 4-20, C-2
- settling time, 3-4
- signal connections
 - analog input
 - common-mode signal rejection considerations, 4-17
 - differential connections
 - considerations, 4-11
 - ground-referenced signal sources, 4-14
 - nonreferenced or floating signal sources, 4-12
 - recommended configuration (table), 4-10
 - single-ended connections
 - considerations, 4-15
 - floating signal sources, 4-16
 - grounded signal sources, 4-16
 - field wiring considerations, 4-40
 - I/O connectors
 - exceeding maximum ratings (caution), 4-1
 - I/O connector details, 4-1
 - I/O connector signal descriptions (table), 4-3
 - I/O signal summary (table), 4-5
 - optional
 - 50-pin E Series connector pin assignments (figure), B-4
 - pin assignments (figure), 4-2
 - power connections, 4-20
 - timing connections
 - DAQ timing connections, 4-22
 - general-purpose timing signal connections, 4-34
 - programmable function input connections, 4-21
 - waveform generation timing connections, 4-31
- signal sources
 - floating signal sources, 4-6
 - ground-referenced signal sources, 4-7
- single-ended connections
 - floating signal sources (RSE input mode), 4-16
 - grounded signal sources (NRSE input mode), 4-16
 - recommended configuration (table), 4-10
 - when to use, 4-15
- SISOURCE signal
 - RTSI bus signal connections (figure), 3-8
 - timing connections, 4-29
 - timing diagram, 4-30
- software drivers, D-1
- software installation, 2-1
- software programming choices
 - NI-DAQ, 1-2
 - overview, 1-2
 - VI Logger, 1-4

specifications

- analog input
 - accuracy information, A-2, A-12
 - amplifier characteristics, A-3, A-13
 - dynamic characteristics, A-3, A-13
 - input characteristics, A-1, A-11
 - stability, A-4, A-14
 - transfer characteristics, A-2, A-12
- analog output
 - accuracy information, A-5, A-15
 - dynamic characteristics, A-7, A-16
 - output characteristics, A-4, A-14
 - stability, A-7, A-16
 - transfer characteristics, A-5, A-15
 - voltage output, A-6, A-15
- calibration, A-9, A-17
- digital I/O, A-8, A-16
- electromagnetic compatibility,
 - A-11, A-19
- environmental, A-10, A-18
- maximum working voltage, A-10, A-18
- physical, A-10, A-18
- power requirement, A-10, A-18
- safety, A-10, A-19
- timing I/O, A-8, A-17
- triggers, A-17
 - digital trigger, A-9
 - RTSI, A-9
- STARTSCAN signal
 - See also* PFI7/STARTSCAN signal
 - input timing (figure), 4-26
 - output timing (figure), 4-27
 - RTSI bus signal connections (figure), 3-8
 - timing connections, 4-25
 - typical posttriggered acquisition (figure), 4-22
 - typical pretriggered acquisition (figure), 4-23
- support
 - technical, D-1
- system integration services, D-1

T

- technical support, D-1
- telephone technical support, D-1
- timing connections
 - DAQ timing connections
 - AIGATE signal, 4-29
 - CONVERT* signal, 4-28
 - EXTSTROBE* signal, 4-31
 - overview, 4-22
 - SCANCLK signal, 4-30
 - SISOURCE signal, 4-29
 - STARTSCAN signal, 4-25
 - TRIG1 signal, 4-23
 - TRIG2 signal, 4-24
 - typical posttriggered acquisition, 4-22
 - typical pretriggered acquisition, 4-23
 - general-purpose timing signal connections
 - FREQ_OUT signal, 4-40
 - GPCTR0_GATE signal, 4-35
 - GPCTR0_OUT signal, 4-36
 - GPCTR0_SOURCE signal, 4-34
 - GPCTR0_UP_DOWN signal, 4-36
 - GPCTR1_GATE signal, 4-37
 - GPCTR1_OUT signal, 4-38
 - GPCTR1_SOURCE signal, 4-37
 - GPCTR1_UP_DOWN signal, 4-39
 - overview, 4-20
 - programmable function input connections, 4-21
 - timing I/O connections (figure), 4-21
 - waveform generation timing connections
 - overview, 4-31
 - UISOURCE signal, 4-33
 - UPDATE* signal, 4-32
 - WFTRIG signal, 4-31
- timing I/O
 - questions about, C-7
 - specifications, A-8, A-17

training

customer, D-1

TRIG1 signal

See also PFI0/TRIG1 signal

input timing (signal), 4-24

output timing (figure), 4-24

RTSI bus signal connections (figure), 3-8

timing connections, 4-23

typical posttriggered acquisition
(figure), 4-22

typical pretriggered acquisition
(figure), 4-23

TRIG2 signal

See also PFI1/TRIG2 signal

input timing (figure), 4-25

output timing (figure), 4-25

RTSI bus signal connections (figure), 3-8

timing connections, 4-24

typical pretriggered acquisition
(figure), 4-23

triggers

specifications, A-9, A-17

troubleshooting resources, D-1

U

UISOURCE

RTSI bus signal connections (figure), 3-8

UISOURCE signal

timing connections, 4-33

timing diagram, 4-34

unpacking the device, 1-5

UPDATE* signal

See also PFI5/UPDATE* signal

input timing (figure), 4-33

output timing (figure), 4-33

RTSI bus signal connections (figure), 3-8

timing connections, 4-32

V

VCC signal

signal summary (table), 4-5

VI Logger application software, 1-4

voltage output specifications, A-6, A-15

W

waveform generation

glitches in, C-4

synchronization, C-4

waveform generation timing signal
connections

UISOURCE signal, 4-33

UPDATE* signal, 4-32

WFTRIG signal, 4-31

Web

professional services, D-1

technical support, D-1

WFTRIG signal

See also PFI6/WFTRIG signal

input timing (diagram), 4-32

output timing (diagram), 4-32

RTSI bus signal connections (figure), 3-8

timing connections, 4-31

worldwide technical support, D-1